

FTLC1122RDNL-AO

Finisar® FTLC1122RDNL Compatible TAA 100GBase-LR4 CFP2 Transceiver (SMF, 1310nm, 10km, LC, DOM)

Features

- Compliant with 100GBase-LR4 and 411-9D1F
- Integrated LAN WDM EML TOSA/ROSA Up to 10km Reach Over SMF
- Up to 103.125Gbps to 111.81Gbps Transmission Lines
- Single 3.3V Power Supply
- Power Consumption: 6W
- Duplex LC Optical Receptacle
- RoHS Compliant and Lead-Free
- Operating Temperature: 0 to 70 Celsius



Applications

- OTU4 Operation
- 100GBase Ethernet

Product Description

This Finisar® FTLC1122RDNL compatible CFP2 transceiver provides 100GBase-LR4 throughput up to 10km over single-mode fiber (SMF) using a wavelength of 1310nm via an LC connector. Our transceiver is built to meet or exceed OEM specifications and is guaranteed to be 100% compatible with Finisar®. It has been programmed, uniquely serialized, and tested for data-traffic and application to ensure that it will initialize and perform identically. All of our transceivers comply with Multi-Source Agreement (MSA) standards to provide seamless network integration. Additional product features include Digital Optical Monitoring (DOM) support which allows access to real-time operating parameters. This transceiver is Trade Agreements Act (TAA) compliant. We stand behind the quality of our products and proudly offer a limited lifetime warranty.

AddOn's transceivers are RoHS compliant and lead-free.

TAA refers to the Trade Agreements Act (19 U.S.C. & 2501-2581), which is intended to foster fair and open international trade. TAA requires that the U.S. Government may acquire only "U.S.-made or designated country end products."



Absolute Maximum Ratings

Parameter	Symbol	Min.	Typ.	Max.	Unit	Notes
Operating Case Temperature	Tc	0		70	°C	
Storage Temperature	Tstg	-40		85	°C	
Power Supply Voltage	Vcc	-0.3		4	V	
Signal Input Voltage		Vcc-0.3		Vcc+0.3	V	
Receive Input Optical Power (Damage Threshold)	Pdmg			5.0	dBm	
Signaling Speed Per Lane			25.78125 ± 100ppm 27.9525 ± 20ppm		Gbps	

Low-Speed Electrical Characteristics

Parameter	Symbol	Min.	Typ.	Max.	Unit	Notes
Power Supply Voltage	Vcc	3.13	3.3	3.47	V	1
Power Supply Current	Icc			450	mA	
Power Dissipation	PD			6.0	W	
Power Dissipation (Low-Power Mode)	PDLP			2.0	W	
Low-Speed Control and Sense Signals (3.3V LVCMOS)						
Output Low Voltage	VOL			0.2	V	IOH = 100µA
Output High Voltage	VOH	Vcc-0.2			V	IOH = -100µA
Input Low Voltage	VIL	-0.3		0.8	V	
Input High Voltage	VIH	2		Vcc3+ 0.3	V	
Input Leakage Current	Iin	-10		10	µA	
Low-Speed Control and Sense Signals (1.2V LVCMOS)						
Output Low Voltage	VOL	-0.3		0.2	V	
Output High Voltage	VOH	1.0		1.5	V	
Output Low Current	Iol	4			mA	
Output High Current	Ioh			-4	mA	
Input Low Voltage	VIL	-0.3		0.36	V	
Input High Voltage	VIH	0.84		1.5	V	
Input Leakage Current	Iin	-100		100	µA	
Input Capacitance	C			10	pF	
MDC Clock Rate		0.1		4	MHz	

Notes:

1. With respect to GND.

High-Speed Electrical Characteristics

Parameter	Symbol	Min.	Typ.	Max.	Unit	Notes
Transmitter Electrical Input from Host						
Differential Voltage Pk-Pk		100		1200	mV	
Common-Mode Noise (RMS)				17.5	mV	
Differential Termination Mismatch				10	%	
Transition Time		10			ps	20-80%
Common-Mode Voltage		-0.3		2.8	V	
Eye Width	EW15	0.46			UI	At 10 ⁻¹⁵ Probability
Eye Height	EH15	100			mV	At 10 ⁻¹⁵ Probability
Receiver Electrical Output from Host						
Differential Voltage Pk-Pk		100		1200	mV	
Common-Mode Noise (RMS)				17.5	mV	
Differential Termination Mismatch				10	%	
Transition Time		9.5			ps	20-80%
Vertical Eye Closure	VEC			6.5	dB	
Eye Width	EW15	0.57			UI	At 10 ⁻¹⁵ Probability
Eye Height	EH15	240		mV		At 10 ⁻¹⁵ Probability

Optical Characteristics for 100GBase-LR4

Parameter	Symbol	Min.	Typ.	Max.	Unit	Notes
Transmitter						
Center Wavelength	λ_0	1294.53	1295.56	1296.59	nm	
	λ_1	1299.02	1300.05	1301.09	nm	
	λ_2	1303.54	1304.58	1305.63	nm	
	λ_3	1308.09	1309.14	1310.19	nm	
Total Output Power	POUT			10.5	dBm	
Transmit OMA Per Lane		-1.3		4.5	dBm	
Average Launch Power Per lane		-4.3		4.5	dBm	
SMSR		30			dB	
Optical Extinction Ratio	ER	4			dB	
Average Launch Power Off Per Lane	Poff			-30	dBm	
RIN	RIN			-130	dB/Hz	
Output Eye Mask Definitions: {X1, X2, X3, Y1, Y2, Y3}		{0.25, 0.4, 0.45, 0.25, 0.28, 0.4}				1
Receiver						
Center Wavelength	λ_0	1294.53	1295.56	1296.59	nm	
	λ_1	1299.02	1300.05	1301.09	nm	
	λ_2	1303.54	1304.58	1305.63	nm	
	λ_3	1308.09	1309.14	1310.19	nm	
Receiver Power (OMA) Per Lane	RXPx			4.5	dBm	
Average Input Power Per Channel	RxPWR	-10.6		4.5	dBm	2
Receiver Sensitivity (OMA) Per Lane	RxSENS			-8.6	dBm	
LOS Assert	LOSA			-12	dBm	
LOS De-Assert	LOSD	-30			dBm	
Receiver Reflectance	RR			-26	dB	

Notes:

1. Hit ratio 5×10^{-5} .
2. Measured with a PRBS³¹-1 test pattern, @25.78Gbps, and BER $<10^{-12}$.

Optical Characteristics for OTU4 411-9D1F

Parameter	Symbol	Min.	Typ.	Max.	Unit	Notes
Transmitter						
Center Wavelength	λ_0	1294.53	1295.56	1296.59	nm	
	λ_1	1299.02	1300.05	1301.09	nm	
	λ_2	1303.54	1304.58	1305.63	nm	
	λ_3	1308.09	1309.14	1310.19	nm	
Total Output Power	POUT			8.9	dBm	
Average Launch Power Per lane		-2.5		2.9	dBm	
SMSR		30			dB	
Optical Extinction Ratio	ER	7			dB	
Average Launch Power Off Per Lane	Poff			-30	dBm	
Output Eye Mask Definitions: {X1, X2, X3, Y1, Y2, Y3}		{0.25, 0.4, 0.45, 0.25, 0.28, 0.4}				3
Receiver						
Center Wavelength	λ_0	1294.53	1295.56	1296.59	nm	
	λ_1	1299.02	1300.05	1301.09	nm	
	λ_2	1303.54	1304.58	1305.63	nm	
	λ_3	1308.09	1309.14	1310.19	nm	
Average Input Power Per Channel	RxPWR	-10.6		4.5	dBm	
Equivalent Sensitivity Per Channel	RxSens			-10.3	dBm	4
LOS De-Assert	LOSD	-30			dBm	
LOS Assert	LOSA			-12	dBm	
Receiver Reflectance	RR			-26	dB	

Notes:

1. Hit ratio 5×10^{-5} .
2. Measured with a PRBS³¹-1 test pattern, @25.95Gbps, and BER < 1×10^{-6} .

Pin Descriptions

Pin	Symbol	Type	Name/Description	Notes
1	GND		Module Ground.	
2	(TX_MCLK-)	CML	Not Connected.	
3	(TX_MCLK+)	CML	Not Connected.	
4	GND		Module Ground.	
5	N.C.		Not Connected.	
6	N.C.		Not Connected.	
7	3.3V_GND		3.3V Ground. Tied w/Module Ground.	
8	3.3V_GND		3.3V Ground. Tied w/Module Ground.	
9	3.3V		3.3V Module Supply Voltage.	
10	3.3V		3.3V Module Supply Voltage.	
11	3.3V		3.3V Module Supply Voltage.	
12	3.3V		3.3V Module Supply Voltage.	
13	3.3V_GND		3.3V Ground. Tied w/Module Ground.	
14	3.3V_GND		3.3V Ground. Tied w/Module Ground.	
15	VND_IO_A		Module Vendor IO A. Do Not Connect.	
16	VND_IO_B		Module Vendor IO B. Do Not Connect.	
17	PRG_CNTL1	LVC MOS1	Programmable Control 1. MSA default: TRXIC_RSTn. "0": reset; "1" or NC: not used.	
18	PRG_CNTL2	LVC MOS1	Programmable Control 2. MSA default: hardware interlock LSB; default "0": ≤9W.	
19	PRG_CNTL3	LVC MOS1	Programmable Control 3. MSA default: hardware interlock MSB; default "1": ≤9W.	
20	PRG_ALARM1	LVC MOS	Programmable Alarm 1. MSA default: HIPWR_ON; "1" module power-up completed; "0": module not high powered up.	
21	PRG_ALARM2	LVC MOS	Programmable Alarm 2. MSA default: MOD_Ready; "1" Ready; "0": Not Ready.	
22		LVC MOS		
23	GND		Module Ground.	
24	Tx_DIS	LVC MOS1	Transmitter disables for all lanes; "1" or NC: transmitter disables; "0": transmitter enabled.	
25	Rx_LOS	LVC MOS	Receiver loss of optical signal; "1": Low optical signal, "0": normal condition.	
26	MOD_LOPWR	LVC MOS1	Module low-power mode; "1" or NC: module in low-power mode, "0": power enabled.	
27	MOD_ABS	GND	Module Absent; "1" or NC: module absent, "0": module present. Pull-up resistor on host.	
28	MOD_RST-	LVC MOS2	Module Reset, "0": reset the module; "1" or NC: module enabled.	
29	GLB_ALARM-	LVC MOS	Global Alarm. "0": alarm in any MDIO alarm register; "1": no alarm condition. Pull-up resistor on host.	
30	GND		Module Ground.	
31	MDC	1.2V CMOS	Management Interface Clock Input.	
32	MDIO	1.2V CMOS	Management Interface Bi-Directional Data.	
33	PRTADR0	1.2V CMOS	MDIO Physical Port Address Bit 0.	
34	PRTADR1	1.2V CMOS	MDIO Physical Port Address Bit 1.	
35	PRTADR2	1.2V CMOS	MDIO Physical Port Address Bit 2.	

36	VND_IO_C		Module Vendor IO C. Do Not Connect.	
37	VND_IO_D		Module Vendor IO D. Do Not Connect.	
38	VND_IO_E		Module Vendor IO E. Do Not Connect.	
39	3.3V_GND		3.3V Ground. Tied w/Module Ground.	
40	3.3V_GND		3.3V Ground. Tied w/Module Ground.	
41	3.3V		3.3V Module Supply Voltage.	
42	3.3V		3.3V Module Supply Voltage.	
43	3.3V		3.3V Module Supply Voltage.	
44	3.3V		3.3V Module Supply Voltage.	
45	3.3V_GND		3.3V Ground. Tied w/Module Ground.	
46	3.3V_GND		3.3V Ground. Tied w/Module Ground.	
47	N.C.		Not Connected.	
48	N.C.		Not Connected.	
49	GND		Module Ground.	
50	(RX_MCLK-)	CML	Not Connected.	
51	(RX_MCLK+)	CML	Not Connected.	
52	GND		Module Ground.	
53	GND		Module Ground.	
54	N.C.		Not Connected.	
55	N.C.		Not Connected.	
56	GND		Module Ground.	
57	Rx0+		25Gbps Receiver Data; Lane 0.	
58	Rx0-		25Gbps Receiver Data Bar; Lane 0.	
59	GND		Module Ground.	
60	Rx1+		25Gbps Receiver Data; Lane 1.	
61	Rx1-		25Gbps Receiver Data Bar; Lane 1.	
62	GND		Module Ground.	
63	N.C.		Not Connected.	
64	N.C.		Not Connected.	
65	GND		Module Ground.	
66	N.C.		Not Connected.	
67	N.C.		Not Connected.	
68	GND		Module Ground.	
69	Rx2+		25Gbps Receiver Data; Lane 2.	
70	Rx2-		25Gbps Receiver Data Bar; Lane 2.	
71	GND		Module Ground.	
72	Rx3+		25Gbps Receiver Data; Lane 3.	
73	Rx3-		25Gbps Receiver Data Bar; Lane 3.	
74	GND		Module Ground.	
75	N.C.		Not Connected.	
76	N.C.		Not Connected.	
77	GND		Module Ground.	

78	(REFCLK+)	CML	Module Reference Clock. Not Connected.	
79	(REFCLK-)	CML	Module Reference Clock. Not Connected.	
80	GND		Module Ground.	
81	N.C.		Not Connected.	
82	N.C.		Not Connected.	
83	GND		Module Ground.	
84	Tx0+		25Gbps Transmitter Data; Lane 0.	
85	Tx0-		25Gbps Transmitter Data Bar; Lane 0.	
86	GND		Module Ground.	
87	Tx1+		25Gbps Transmitter Data; Lane 1.	
88	Tx1-		25Gbps Transmitter Data Bar; Lane 1.	
89	GND		Module Ground.	
90	N.C.		Not Connected.	
91	N.C.		Not Connected.	
92	GND		Module Ground.	
93	N.C.		Not Connected.	
94	N.C.		Not Connected.	
95	GND		Module Ground.	
96	Tx2+		25Gbps Transmitter Data; Lane 2.	
97	Tx2-		25Gbps Transmitter Data Bar; Lane 2.	
98	GND		Module Ground.	
99	Tx3+		25Gbps Transmitter Data; Lane 3.	
100	Tx3-		25Gbps Transmitter Data Bar; Lane 3.	
101	GND		Module Ground.	
102	N.C.		Not Connected.	
103	N.C.		Not Connected.	
104	GND		Module Ground.	

Notes:

1. Pulled up with 4.7k Ω -10k Ω to 3.3V inside the module.
2. Pulled up with 4.7k Ω -10k Ω to GND inside the module.

Electrical Pad Layout

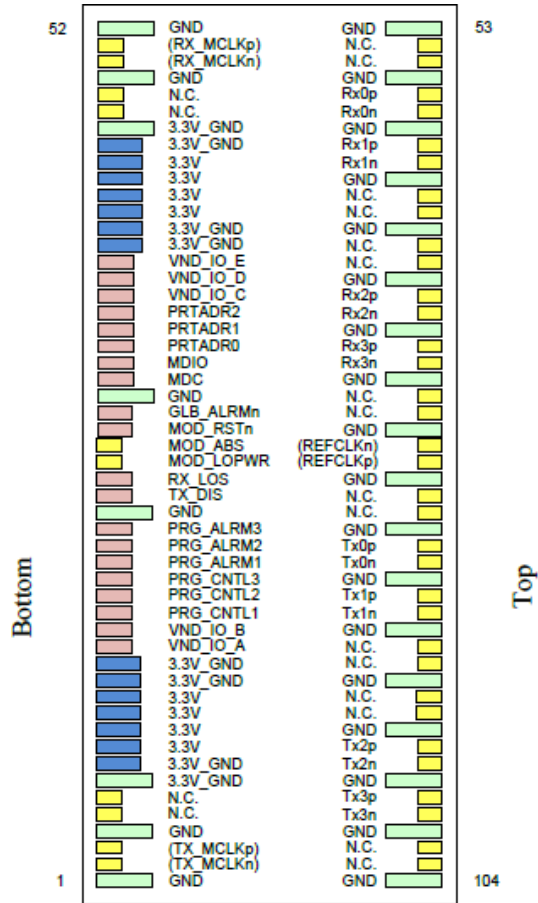

Block Diagram

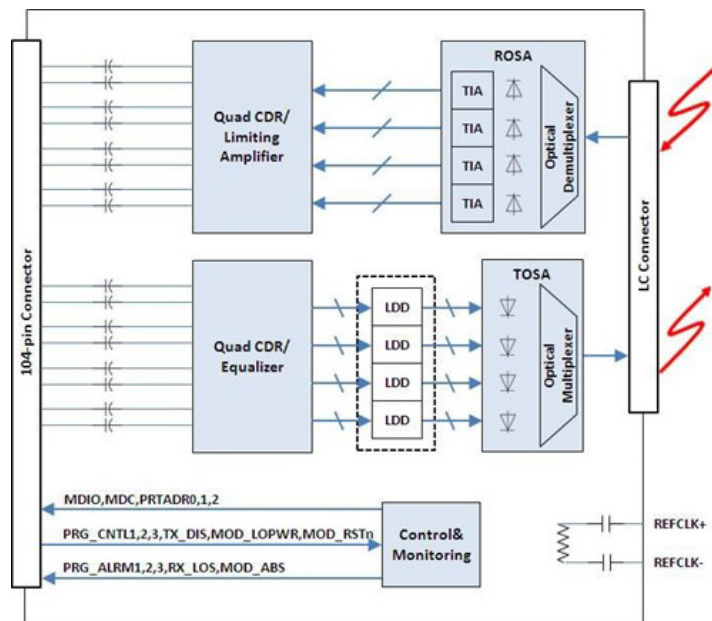

Mechanical Specifications

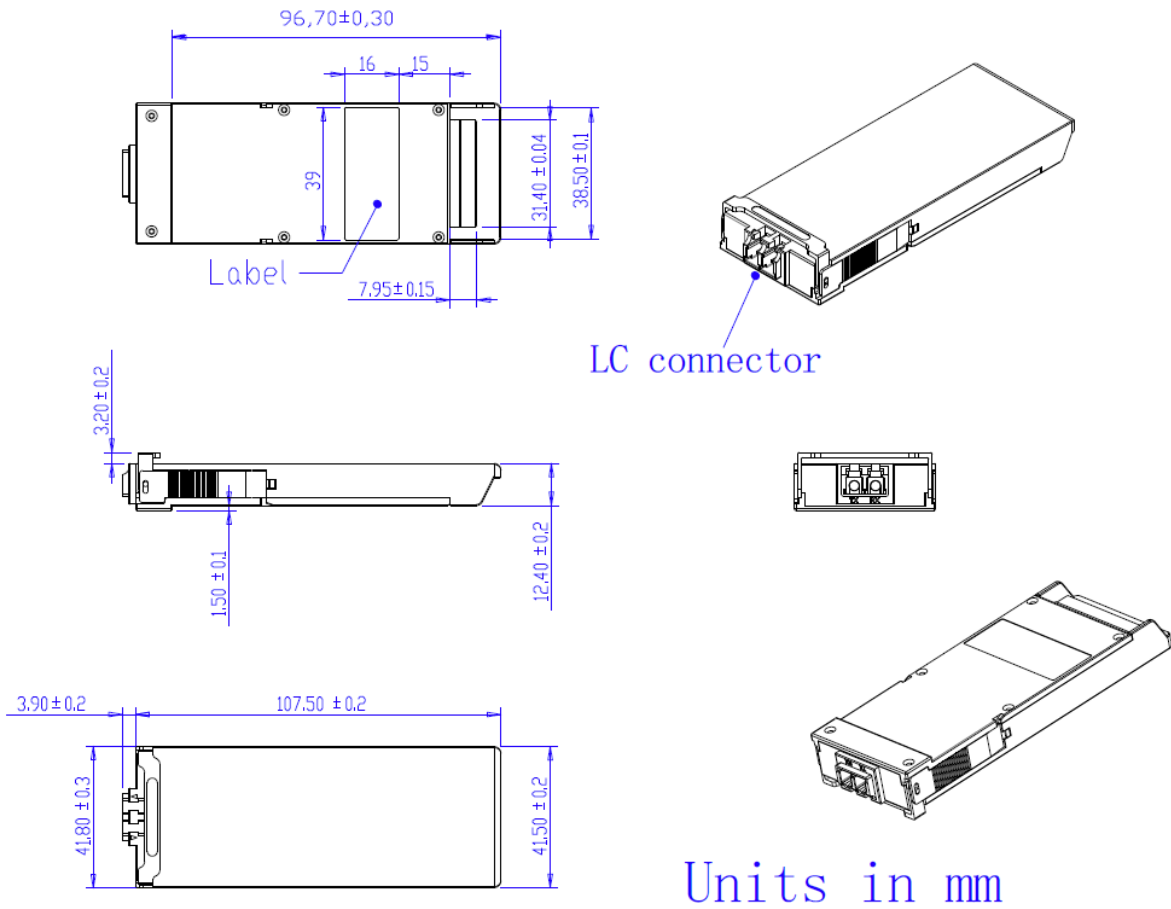

About AddOn Networks

In 1999, AddOn Networks entered the market with a single product. Our founders fulfilled a severe shortage for compatible, cost-effective optical transceivers that compete at the same performance levels as leading OEM manufacturers. Adhering to the idea of redefining service and product quality not previously had in the fiber optic networking industry, AddOn invested resources in solution design, production, fulfillment, and global support.

Combining one of the most extensive and stringent testing processes in the industry, an exceptional free tech support center, and a consistent roll-out of innovative technologies, AddOn has continually set industry standards of quality and reliability throughout its history.

Reliability is the cornerstone of any optical fiber network and is ingrained in AddOn's DNA. It has played a key role in nurturing the long-term relationships developed over the years with customers. AddOn remains committed to exceeding industry standards with certifications ranging from NEBS Level 3 to ISO 9001:2015 with every new development while maintaining the signature reliability of its products.



U.S. Headquarters

Email: sales@addonnetworks.com

Telephone: +1 877.292.1701

Fax: 949.266.9273

Europe Headquarters

Email: salesemea@addonnetworks.com

Telephone: +44 1285 842070