

## QSFP-100GB-ER4L-RX-AO

MSA and TAA Compliant 100GBase-ER4L QSFP28 Monitor (SMF, 1310nm, 40km w/host FEC, LC, DOM, RX only)

### Features:

- QSFP28 MSA Compliant
- Supports 103.125 Gbps Data Rate
- 4x 25.781Gbps Serial Electrical Interface (CEI-28G-VSR)
- 4x PIN + SOA LAN-WDM Receivers
- Power Dissipation < 3W (Power Class 4)
- Single +3.3V Power Supply
- Commercial Temperature 0 to 70 Celsius
- Duplex LC Connector
- Hot pluggable
- RoHS Compliant and Lead-free



### Applications:

- 100 Gigabit Ethernet Monitoring

### Product Description

This MSA and TAA compliant QSFP28 monitor provides 100GBase-ER4L receive only throughput up to 40km over single-mode fiber (SMF) using a wavelength of 1310nm via an LC connector. It is guaranteed to be 100% compatible with the equivalent MSA compliant monitor. This easy to install, hot swappable monitor has been programmed, uniquely serialized and data-traffic and application tested to ensure that it will initialize and perform identically. Digital optical monitoring (DOM) support is also present to allow access to real-time operating parameters. This monitor is Trade Agreements Act (TAA) compliant. We stand behind the quality of our products and proudly offer a limited lifetime warranty.

AddOn's Transceivers are RoHS compliant and lead-free.

TAA refers to the Trade Agreements Act (19 U.S.C. & 2501-2581), which is intended to foster fair and open international trade. TAA requires that the U.S. Government may acquire only "U.S. – made or designated country end products."



## Regulatory Compliance

- ESD to the Electrical PINs: compatible with MIL-STD-883E Method 3015.4
- ESD to the LC Receptacle: compatible with IEC 61000-4-3
- EMI/EMC: compatible with FCC Part 15 Subpart B Rules, EN55022:2010
- Laser Eye Safety: compatible with FDA 21CFR, EN60950-1& EN (IEC) 60825-1,2
- RoHS compliant with EU RoHS 2.0 directive 2015/863/EU

## Absolute Maximum Ratings

Parameter	Symbol	Min.	Typ.	Max.	Unit
Maximum Supply Voltage	Vcc	-0.3	3.3	3.6	V
Storage Temperature	Tstg	-40		85	°C
Operating Case Temperature	Tc	0		70	°C
Relative Humidity (Non-Condensing)	RH	5		85	%
Data Rate Per Lane			25.78125		Gbps

## Electrical Characteristics

Parameter	Symbol	Min.	Typ.	Max.	Unit	Notes
Supply Voltage	Vcc	3.135	3.3	3.465	V	
Power Supply Current	Icc			900	mA	
Power Dissipation	P <sub>D</sub>			3	W	
Differential Termination Resistance Mismatch				10	%	At 1 MHz
Differential Data Output Swing	V <sub>OUT</sub> , pp	100		400	mVp-p	1
	V <sub>OUT</sub> , pp	300		600	mVp-p	1
	V <sub>OUT</sub> , pp	400		800	mVp-p	1
	V <sub>OUT</sub> , pp	600		1200	mVp-p	1
Common-Mode Noise (RMS)	V <sub>rms</sub>			17.5	mV	
Transition Time	T <sub>r</sub> /T <sub>f</sub>	12			ps	20-80%
Eye Width	EW15	0.57			UI	
Eye Height	EH15	228			mV	

### Notes:

1. Output voltage can be set in 4 discrete ranges via I<sup>2</sup>C. Default range is 400 – 800mV.

## Receiver Optical Characteristics

Parameter	Symbol	Min.	Typ.	Max.	Unit	Notes
<b>Receiver</b>						
<b>Operating Wavelengths</b>	L0	1294.53	1295.56	1296.59	nm	
	L1	1299.02	1300.05	1301.09	nm	
	L2	1303.54	1304.58	1305.63	nm	
	L3	1308.09	1309.14	1310.19	nm	
<b>Average Receiver Power Per Lane</b>		-20.9		-3.5	dBm	
<b>Receiver Power Per Lane (OMA)</b>				-3.5	dBm	
<b>Receiver Sensitivity Per Lane (OMA)</b>	S			-21.4	dBm	1
<b>Receiver Sensitivity Per Lane (OMA)</b>	S			-18.4	dBm	2
<b>Difference in Receive Power Between Any Two Lanes (OMA and Average)</b>				4.5	dB	

### Notes:

1. With FEC, 25.78Gbps,  $BER \leq 5 \times 10^{-5}$ ,  $ER > 8\text{dB}$ , PRBS  $2^{31}-1$ .
2. Without FEC, 25.78Gbps,  $BER \leq 10^{-12}$ ,  $ER > 8\text{dB}$ , PRBS  $2^{31}-1$ .

## Pin Descriptions

Pin	Symbol	Name/Descriptions	Ref.
1	GND	Transmitter Ground (Common with Receiver Ground).	1
2	Tx2-	Transmitter Inverted Data Input.	
3	Tx2+	Transmitter Non-Inverted Data output.	
4	GND	Transmitter Ground (Common with Receiver Ground).	1
5	Tx4-	Transmitter Inverted Data Input.	
6	Tx4+	Transmitter Non-Inverted Data output.	
7	GND	Transmitter Ground (Common with Receiver Ground).	1
8	ModSelL	Module Select.	2
9	ResetL	Module Reset.	2
10	VccRx	+3.3V Power Supply Receiver.	
11	SCL	2-Wire serial Interface Clock.	2
12	SDA	2-Wire serial Interface Data.	2
13	GND	Transmitter Ground (Common with Receiver Ground).	1
14	Rx3+	Receiver Non-Inverted Data Output.	
15	Rx3-	Receiver Inverted Data Output.	
16	GND	Transmitter Ground (Common with Receiver Ground).	1
17	Rx1+	Receiver Non-Inverted Data Output.	
18	Rx1-	Receiver Inverted Data Output.	
19	GND	Transmitter Ground (Common with Receiver Ground).	1
20	GND	Transmitter Ground (Common with Receiver Ground).	1
21	Rx2-	Receiver Inverted Data Output.	
22	Rx2+	Receiver Non-Inverted Data Output.	
23	GND	Transmitter Ground (Common with Receiver Ground).	1
24	Rx4-	Receiver Inverted Data Output.	1
25	Rx4+	Receiver Non-Inverted Data Output.	
26	GND	Transmitter Ground (Common with Receiver Ground).	1
27	ModPrsl	Module Present.	
28	IntL	Interrupt.	2
29	VccTx	+3.3V power supply transmitter.	
30	Vcc1	+3.3V power supply.	
31	LPMODE	Low Power Mode.	2
32	GND	Transmitter Ground (Common with Receiver Ground).	1
33	Tx3+	Transmitter Non-Inverted Data Input.	
34	Tx3-	Transmitter Inverted Data Output.	

35	GND	Transmitter Ground (Common with Receiver Ground).	1
36	Tx1+	Transmitter Non-Inverted Data Input.	
37	Tx1-	Transmitter Inverted Data Output.	
38	GND	Transmitter Ground (Common with Receiver Ground).	1

**Notes:**

1. The module signal grounds are isolated from the module case.
2. This is an open collector/drain output that on the host board requires a 4.7KΩ-10KΩ pull-up resistor to the Host\_Vcc.

**Electrical Pin-out Details**

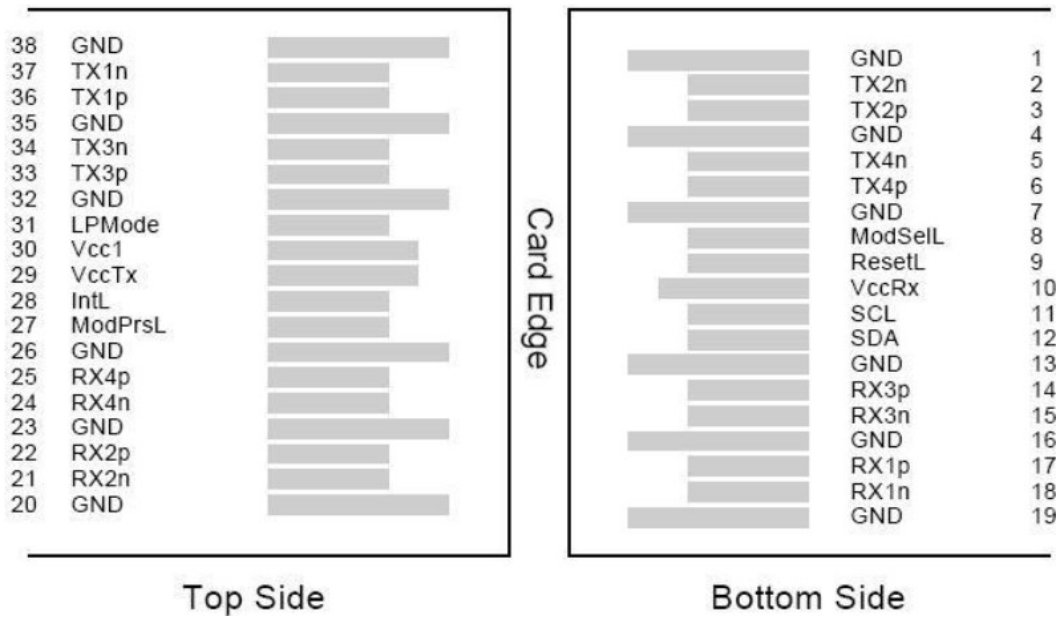

## Recommended Host Board Power Supply Filter Network

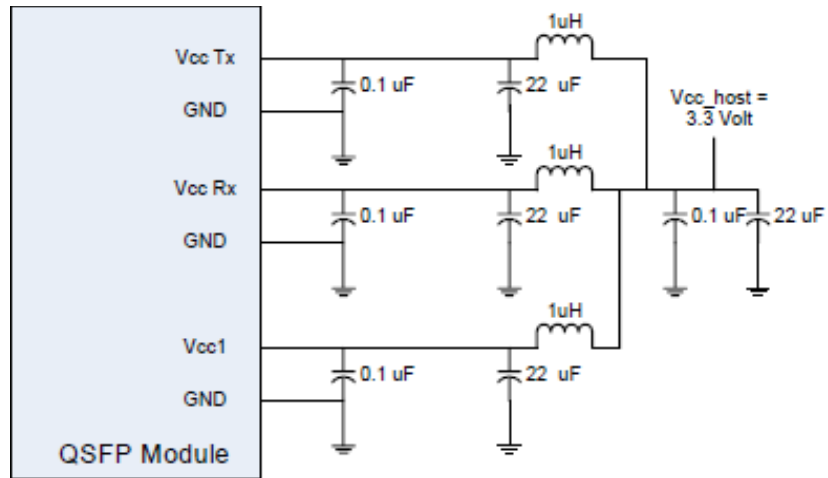

## Mechanical Specifications

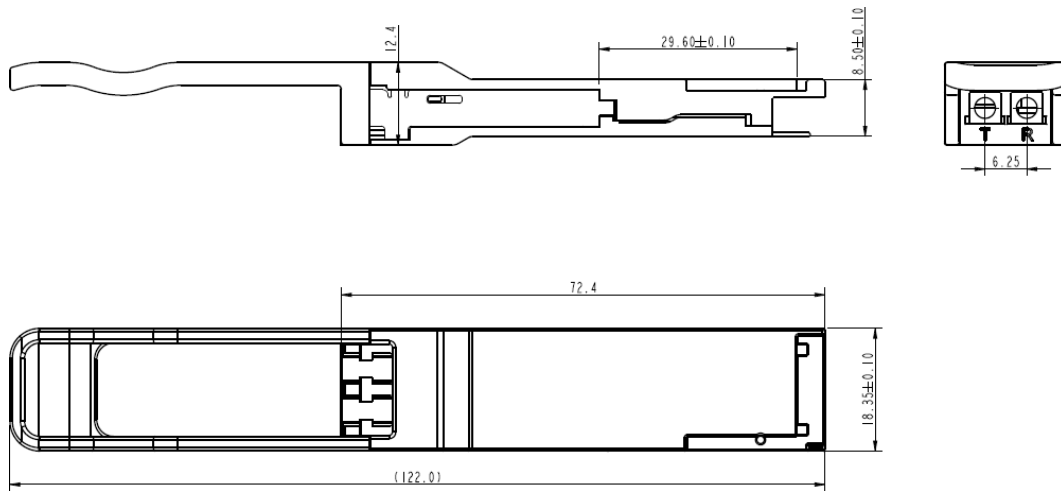

## **About AddOn Networks**

In 1999, AddOn Networks entered the market with a single product. Our founders fulfilled a severe shortage for compatible, cost-effective optical transceivers that compete at the same performance levels as leading OEM manufacturers. Adhering to the idea of redefining service and product quality not previously had in the fiber optic networking industry, AddOn invested resources in solution design, production, fulfillment, and global support.

Combining one of the most extensive and stringent testing processes in the industry, an exceptional free tech support center, and a consistent roll-out of innovative technologies, AddOn has continually set industry standards of quality and reliability throughout its history.

Reliability is the cornerstone of any optical fiber network and is engrained in AddOn's DNA. It has played a key role in nurturing the long-term relationships developed over the years with customers. AddOn remains committed to exceeding industry standards with certifications from ranging from NEBS Level 3 to ISO 9001:2005 with every new development while maintaining the signature reliability of its products.

## **U.S. Headquarters**

Email: [sales@addonnetworks.com](mailto:sales@addonnetworks.com)

Telephone: +1 877.292.1701

Fax: 949.266.9273

## **Europe Headquarters**

Email: [salesupportemea@addonnetworks.com](mailto:salesupportemea@addonnetworks.com)

Telephone: +44 1285 842070