

SFP-1GB-BX74-D-80-I-AO

MSA and TAA 1000Base-BX SFP Transceiver (SMF, 1570nmTx/1490nmRx, 80km, LC, DOM, -40 to 85C)

Features

- INF-8074 and SFF-8472 Compliance
- Single-mode Fiber
- Duplex LC Connector
- Hot Pluggable
- Metal with Lower EMI
- Industrial Temperature -40 to 85 Celsius
- RoHS Compliant and Lead Free
- Excellent ESD Protection



Applications

- 1x Fibre Channel
- 1000Base-BX Ethernet
- Access (FTTx) and Enterprise

Product Description

This MSA Compliant SFP transceiver provides 1000Base-BX throughput up to 80km over single-mode fiber (SMF) using a wavelength of 1570nmTx/1490nmRx via an LC connector. It is built to MSA standards and is uniquely serialized and data-traffic and application tested to ensure that they will integrate into your network seamlessly. Digital optical monitoring (DOM) support is also present to allow access to real-time operating parameters. This transceiver is Trade Agreements Act (TAA) compliant. We stand behind the quality of our products and proudly offer a limited lifetime warranty.

AddOn's transceivers are RoHS compliant and lead-free.

TAA refers to the Trade Agreements Act (19 U.S.C. & 2501-2581), which is intended to foster fair and open international trade. TAA requires that the U.S. Government may acquire only "U.S. – made or designated country end products."



Regulatory Compliance

- ESD to the Electrical PINs: compatible with MIL-STD-883E Method 3015.4.
- ESD to the LC Receptacle: compatible with IEC 61000-4-3.
- EMI/EMC: compatible with FCC Part 15 Subpart B Rules, EN55022:2010.
- Laser Eye Safety: compatible with FDA 21CFR, EN60950-1& EN (IEC) 60825-1, 2.
- RoHS: compliant with EU RoHS 2.0 directive 2015/863/EU.

Absolute Maximum Ratings

Parameter	Symbol	Min.	Typ.	Max.	Unit
Maximum Supply Voltage	Vcc	-0.5		3.6	V
Storage Temperature	Tstg	-40		85	°C
Operating Case Temperature	Tc	-40		85	°C
Operating Humidity	RH	5		85	%
Data Rate (GBE)	DR		1.25		Gbps
Data Rate (FC)	DR		1.063		Gbps

Electrical Characteristics (TOP=25°C, Vcc=3.3 Volts)

Parameter	Symbol	Min.	Typ.	Max.	Unit	Notes
Power Supply Voltage	Vcc	3.15	3.30	3.47	V	
Power Supply Current	Icc			300	mA	
Power Dissipation	P _{DISS}			1	W	
Transmitter						
LVPECL Differential Inputs	VIN	400		1800	mVp-p	1
Input Differential Impedance	ZIN	90	100	110	Ω	2
Tx_Disable	Disable	2		Vcc+0.3	V	
	Enable	0		0.8	V	
Tx_Fault	Fault	2		Vcc+0.3	V	
	Normal	0		0.8	V	
Receiver						
LVPECL Differential Outputs	VOUT	400		2000	mVp-p	1
Output Differential Impedance	ZOUT	90	100	110	Ω	
Tx_Disable Assert Time	T _{off}			10	us	
Rx_LOS	LOS	2		Vcc+0.3	V	
	Normal	0		0.8	V	
MOD_DEF (0.2)	VOH	2.5		Vcc+0.3	V	3
	VOL	0		0.5	V	3

Notes:

1. AC coupled inputs.
2. RIN > 100kΩ @ DC.
3. With Serial ID.

Optical Characteristics

Parameter	Symbol	Min.	Typ.	Max.	Unit	Notes	
Transmitter							
Optical Power (Average)	P_{AVE}	0		5	dBm	1	
Optical Extinction Ratio	ER	9			dB		
Center Wavelength	λ_C	1550	1570	1590	nm		
Spectral Width (-20dB)	$\Delta\lambda$			1	nm		
Side-Mode Suppression Ratio	SMSR	30			dB		
Rise/Fall Time (20-80%)	T_r/T_f			0.26	ns		
POUT @ Tx_Disable Asserted	POUT			-35	dBm		
Output Optical Eye		Compliant with IEEE 802.3					2
Receiver							
Receiver Sensitivity (Average)	R_{AVE}			-24	dBm	3	
Receiver Overload	P_{max}	-3			dBm		
Receiver Wavelength	$R\lambda$	1470	1490	1510	nm		
LOS De-Assert	LOSD			-25	dBm		
LOS Assert	LOSA	-35			dBm		
LOS Hysteresis		0.5			dB		

Notes:

1. Output power is power coupled into a 9/125μm single-mode fiber.
2. Filtered. Measured with a PRBS 2⁷-1 test pattern @1250Mbps.
3. Minimum average optical power is measured at BER less than 1E⁻¹² with 1.25Gbps, 2⁷-1 PRBS, and ER=9dB.

Pin Descriptions

Pin	Symbol	Name/Description	Note
1	VeeT	Transmitter Ground (Common with Receiver Ground).	1
2	Tx_Fault	Transmitter Fault. LVTTTL-O.	2
3	Tx_Disable	Transmitter Disable. Laser output disabled on “high” or “open.” LVTTTL-I.	3
4	SDA	2-Wire Serial Interface Data (Same as MOD-DEF2 in INF-8074i). LVTTTL-I/O.	
5	SCL	2-Wire Serial Interface Clock (Same as MOD-DEF2 in INF-8074i). LVTTTL-I.	
6	MOD_ABS	Module Absent. Connect to VeeT or VeeR in the module.	4
7	RS0	Rate Select 0. Not Used.	5
8	LOS	Loss of Signal indication. “Logic 0” indicates normal operation. LVTTTL-O.	2
9	RS1	Rate Select 1. Not Used.	5
10	VeeR	Receiver Ground (Common with Transmitter Ground).	1
11	VeeR	Receiver Ground (Common with Transmitter Ground).	1
12	RD-	Receiver Inverted Data Out. AC Coupled. CML-O.	
13	RD+	Receiver Non-Inverted Data Out. AC Coupled. CML-O.	
14	VeeR	Receiver Ground (Common with Transmitter Ground).	1
15	VccR	Receiver Power Supply.	
16	VccT	Transmitter Power Supply.	
17	VeeT	Transmitter Ground (Common with Receiver Ground).	1
18	TD+	Transmitter Non-Inverted Data In. AC Coupled. CML-I.	
19	TD-	Transmitter Inverted Data In. AC Coupled. CML-O.	
20	VeeT	Transmitter Ground (Common with Receiver Ground).	1

Notes:

1. The module signal ground contacts, VeeR and VeeT, should be isolated from the module case.
2. This contact is an open collector/drain output and should be pulled up to the Host_Vcc with resistor in the range 4.7kΩ to 10kΩ. Pull-ups can be connected to one or several power supplies; however, the host board design shall ensure that no module contact has voltage exceeding module VccT/R+0.5V.
3. Tx_Disable is an input contact with a 4.7kΩ to 10kΩ pull-up resistor to VccT inside the module.
4. MOD_ABS is connected to VeeT or VeeR in the SFP+ module. The host may pull the contract up to the Host_Vcc with a resistor in the range from 4.7kΩ to 10kΩ. MOD_ABS is asserted “High” when the SFP+ module is physically absent from a host slot.
5. Internally pulled down per SFF-8431.



Pin-Out of Connector Block on the Host Board

Recommended Circuit Schematic

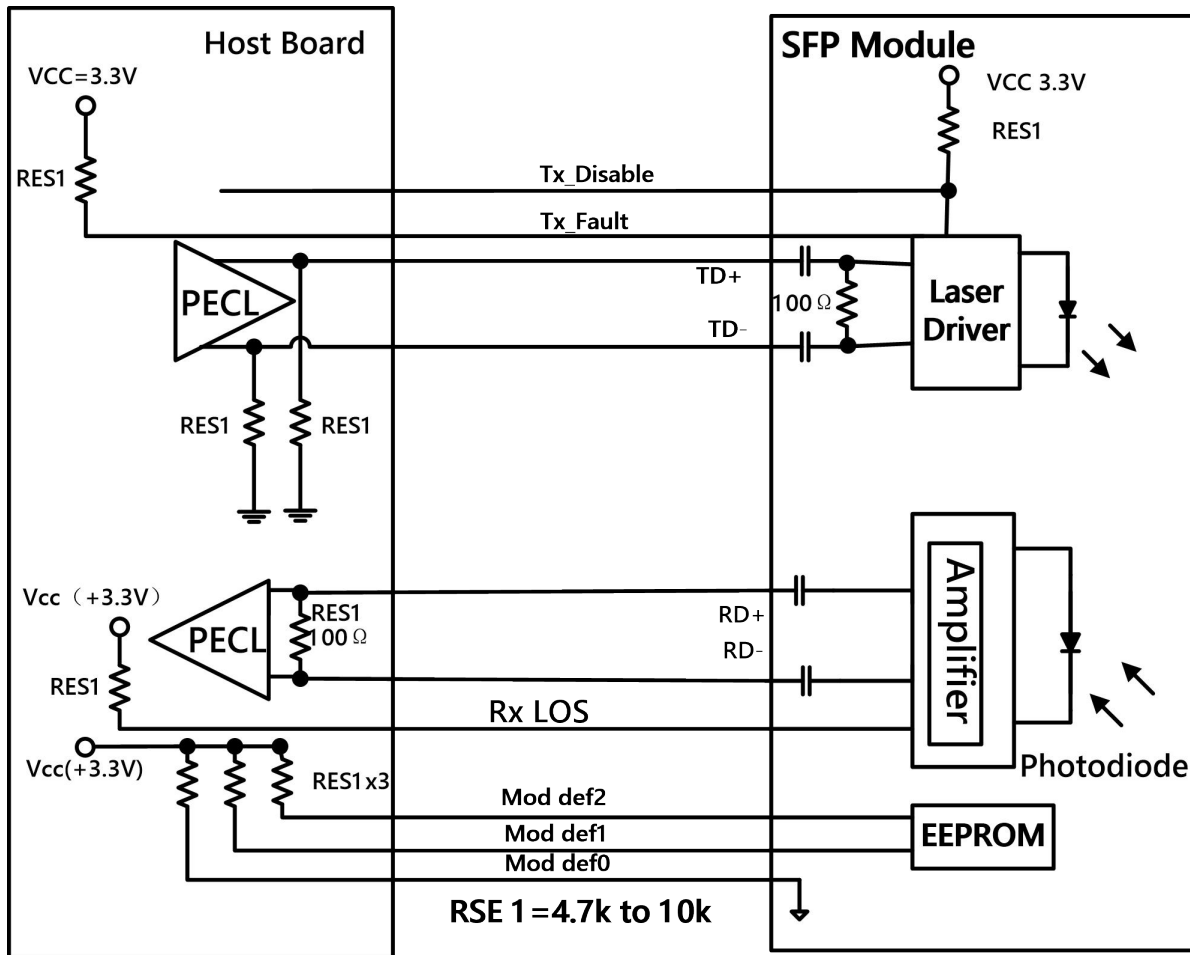

Mechanical Specifications

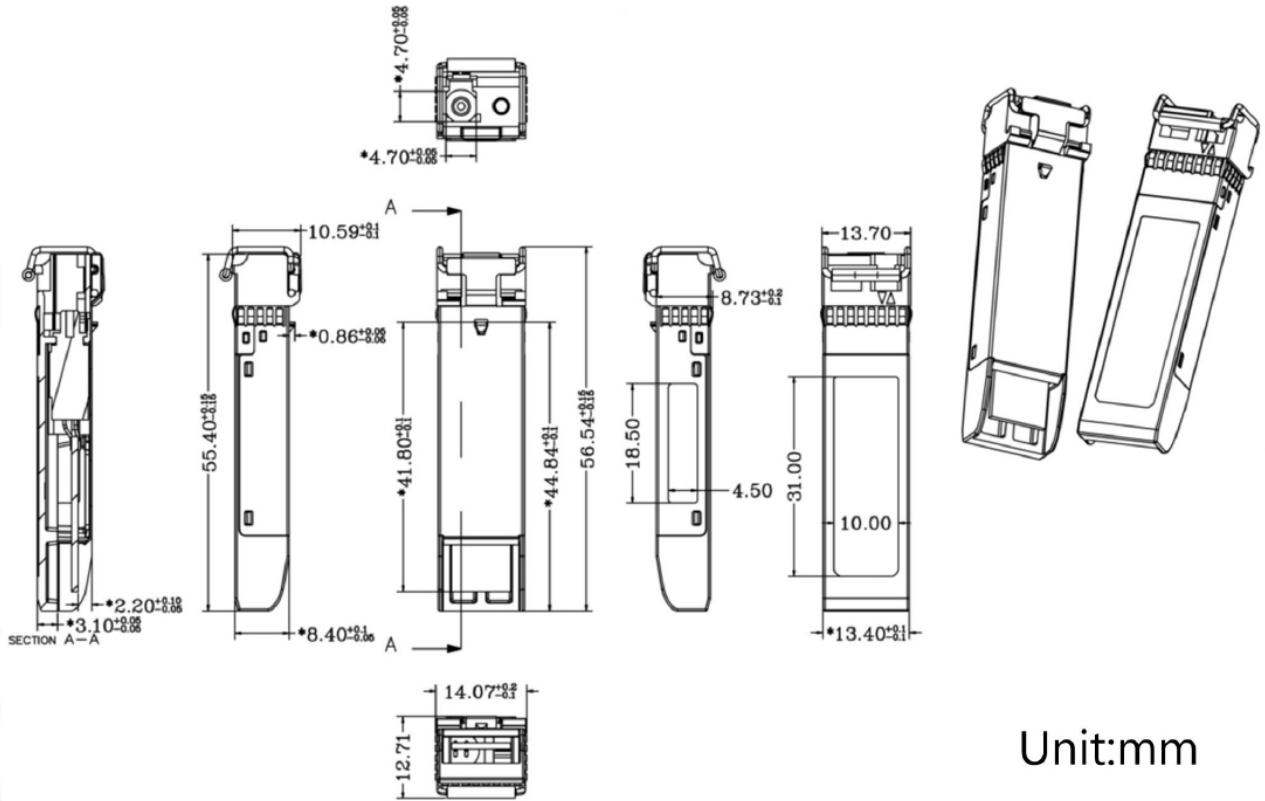

Unit:mm

EEPROM Information

EEPROM memory map-specific data field description is as below:

2 wire address 1010000X (A0h)		2 wire address 1010001X (A2h)	
0	Serial ID Defined by SFP MSA (96 bytes)	0	Alarm and Warning Thresholds (56 bytes)
95		55	Cal Constants (40 bytes)
127	Vendor Specific (32 bytes)	95	Real Time Diagnostic Interface (24 bytes)
	Reserved, SFF8079 (128 bytes)	119	Vendor Specific (8 bytes)
		127	User Writable EEPROM (120 bytes)
		247	Vendor Specific (8 bytes)
255		255	

About AddOn Networks

In 1999, AddOn Networks entered the market with a single product. Our founders fulfilled a severe shortage for compatible, cost-effective optical transceivers that compete at the same performance levels as leading OEM manufacturers. Adhering to the idea of redefining service and product quality not previously had in the fiber optic networking industry, AddOn invested resources in solution design, production, fulfillment, and global support.

Combining one of the most extensive and stringent testing processes in the industry, an exceptional free tech support center, and a consistent roll-out of innovative technologies, AddOn has continually set industry standards of quality and reliability throughout its history.

Reliability is the cornerstone of any optical fiber network and is engrained in AddOn's DNA. It has played a key role in nurturing the long-term relationships developed over the years with customers. AddOn remains committed to exceeding industry standards with certifications from ranging from NEBS Level 3 to ISO 9001:2005 with every new development while maintaining the signature reliability of its products.

U.S. Headquarters

Email: sales@addonnetworks.com

Telephone: +1 877.292.1701

Fax: 949.266.9273

Europe Headquarters

Email: salesupportemea@addonnetworks.com

Telephone: +44 1285 842070