

QDD4-400GB-ER4-AO

MSA and TAA 400GBase-ER4 PAM4 QSFP-DD Transceiver (SMF, 1310nm, 40km, LC, DOM, CMIS 4.0)

Features

- Compliant with IEEE Std 802.3cd
- Compliant with QSFP-DD Management Interface

Specifications

- Compliant with QSFP-DD MSA
- 53.125GBd PAM4x4 Cooled EML
- 26.5625GBd PAM4x8 Electrical Connector
- Duplex LC
- Up to 40km on SMF
- Single 3.3V Power Supply
- RoHS Compliant and Lead-Free
- Operating Temperature: 0 to 70 Celsius



Applications

- 400GBase Ethernet
- Access and Enterprise

Product Description

This MSA Compliant QSFP-DD transceiver provides 400GBase-ER4 throughput up to 40km over single-mode fiber (SMF) using a wavelength of 1310nm via an LC connector. It is built to MSA standards and is uniquely serialized and data-traffic and application tested to ensure that they will integrate into your network seamlessly. Digital optical monitoring (DOM) support is also present to allow access to real-time operating parameters. This transceiver is Trade Agreements Act (TAA) compliant. We stand behind the quality of our products and proudly offer a limited lifetime warranty.

AddOn's transceivers are RoHS compliant and lead-free.

TAA refers to the Trade Agreements Act (19 U.S.C. & 2501-2581), which is intended to foster fair and open international trade. TAA requires that the U.S. Government may acquire only "U.S. – made or designated country end products."



Absolute Maximum Ratings

Parameter	Symbol	Min.	Typ.	Max.	Unit	Notes
Storage Temperature	Tstg	-40		85	°C	
Operating Case Temperature	Tc	0	25	70	°C	
Relative Humidity	RH	15		85	%	
Supply Voltage	Vcc	-0.5		4.0	V	
Data Rate Per Channel			53.125		Gbps	
Modulation Format			PAM4			

Electrical Characteristics

Parameter	Symbol	Min.	Typ.	Max.	Unit	Notes
Power Supply Voltage	Vcc	3.135	3.3	3.465	V	
Power Supply Current	Icc			3.8	A	
Power Dissipation	P _{DISS}			12	W	
Transmitter						
Input Differential Impedance	ZIN		100		Ω	
Differential Data Input Swing	VIN,pp	180		900	mVp-p	
Receiver						
Output Differential Impedance	ZOUT		100		Ω	
Differential Data Input Swing	VOUT,pp	300		850	mVp-p	1

Notes:

1. Internally AC coupled but requires an external 100Ω differential load termination.

Optical Characteristics

Parameter	Symbol	Min.	Typ.	Max.	Unit	Notes
Transmitter						
Center Wavelength	λ_C	1304.06		1305.1	nm	1
		1306.33		1307.38		
		1308.61		1309.66		
		1310.9		1311.96		
Side-Mode Suppression Ratio	SMSR	30			dB	
Total Average Launch Power	PT			10	dBm	
Average Launch Power Per Lane	P	1.5		7.1	dBm	
Outer Optical Modulation Amplitude Per Lane (Min.)	OMA _{outer}	4.5		7.9	dBm	
Transmitter and Dispersion Eye Closure for PAM4 (TDECQ) Per Lane	TDECQ			3.9	dB	
Transmitter Eye Closure for PAM4 (TECQ) Per Lane	TECQ			3.9	dB	
TDECQ-TECQ				2.7	dB	
Extinction Ratio	ER	6			dB	
Average Launch Power of Off Transmitter Per Lane	P _{off}			-30	dBm	
Optical Return Loss Tolerance	ORLT			15	dB	
Transmitter Reflectance				-26	dB	
Receiver						
Center Wavelength	λ_C	1304.06		1305.1	nm	
		1306.33		1307.38		
		1308.61		1309.66		
		1310.9		1311.96		
Average Receiver Power Per Lane (P_{avg})		-16.2		-3.4	dBm	
Receiver Overload (Average Power) Per Lane		-3.4			dBm	
Damage Threshold		-2.4			dBm	
Receive Power Per Lane (OMA_{outer})				-2.6	dBm	2
Receiver Sensitivity Per Lane (OMA_{outer})				-14	dBm	2
Stressed Receiver Sensitivity Per Lane (OMA_{outer})				-11.5	dBm	
LOS Assert	LOSA			-20	dBm	
LOS De-Assert	LOSD			-17	dBm	
LOS Hysteresis		0.5			dB	

Notes:

1. The typical wavelengths compliant with 1310nm nLWDM wavelength grids.
2. Measured with PRBS31Q test pattern @53.125Gbps, PAM4, and BER<2.4E⁻⁴.

Pin Descriptions

Pin	Symbol	Name/Description	Notes
1	GND	Module Ground.	1
2	Tx2-	Transmitter Inverted Data Input.	
3	Tx2+	Transmitter Non-Inverted Data Output.	
4	GND	Module Ground.	1
5	Tx4-	Transmitter Inverted Data Input.	
6	Tx4+	Transmitter Non-Inverted Data Output.	
7	GND	Module Ground.	1
8	ModSelL	Module Select.	
9	ResetL	Module Reset.	
10	VccRx	+3.3V Receiver Power Supply.	2
11	SCL	2-Wire Serial Interface Clock.	
12	SDA	2-Wire Serial Interface Data.	
13	GND	Module Ground.	1
14	Rx3+	Receiver Non-Inverted Data Output.	
15	Rx3-	Receiver Inverted Data Output.	
16	GND	Module Ground.	1
17	Rx1+	Receiver Non-Inverted Data Output.	
18	Rx1-	Receiver Inverted Data Output.	
19	GND	Module Ground.	1
20	GND	Module Ground.	1
21	Rx2-	Receiver Inverted Data Output.	
22	Rx2+	Receiver Non-Inverted Data Output.	
23	GND	Module Ground.	1
24	Rx4-	Receiver Inverted Data Output.	
25	Rx4+	Receiver Non-Inverted Data Output.	
26	GND	Module Ground.	1
27	ModPrsL	Module Present.	
28	IntL	Interrupt.	
29	VccTx	+3.3V Transmitter Power Supply.	2
30	Vcc1	+3.3V Power Supply.	2
31	LPMODE	Low-Power Mode.	
32	GND	Module Ground.	1
33	Tx3+	Transmitter Non-Inverted Data Input.	
34	Tx3-	Transmitter Inverted Data Output.	
35	GND	Module Ground.	1
36	Tx1+	Transmitter Non-Inverted Data Input.	
37	Tx1-	Transmitter Inverted Data Output.	
38	GND	Module Ground.	1
39	GND	Module Ground.	1

40	Tx6-	Transmitter Inverted Data Input.	
41	Tx6+	Transmitter Non-Inverted Data Output.	
42	GND	Module Ground.	1
43	Tx8-	Transmitter Inverted Data Input.	
44	Tx8+	Transmitter Non-Inverted Data Output.	
45	GND	Module Ground.	1
46	Reserved	For Future Use.	3
47	VS1	Module Vendor-Specific 1.	3
48	VccRx1	+3.3V Receiver Power Supply.	2
49	VS2	Module Vendor-Specific 2.	3
50	VS3	Module Vendor-Specific 3.	3
51	GND	Module Ground.	1
52	Rx7+	Receiver Non-Inverted Data Output.	
53	Rx7-	Receiver Inverted Data Output.	
54	GND	Module Ground.	1
55	Rx5+	Receiver Non-Inverted Data Output.	
56	Rx5-	Receiver Inverted Data Output.	
57	GND	Module Ground.	1
58	GND	Module Ground.	1
59	Rx6-	Receiver Inverted Data Output.	
60	Rx6+	Receiver Non-Inverted Data Output.	
61	GND	Module Ground.	1
62	Rx8-	Receiver Inverted Data Output.	
63	Rx8+	Receiver Non-Inverted Data Output.	
64	GND	Module Ground.	1
65	NC	Not Connected.	3
66	Reserved	For Future Use.	3
67	VccTx1	+3.3V Transmitter Power Supply.	2
68	Vcc2	+3.3V Power Supply.	2
69	ePPS	Precision Time Protocol (PTP) Reference Clock Input.	3
70	GND	Module Ground.	1
71	Tx7+	Transmitter Non-Inverted Data Input.	
72	Tx7-	Transmitter Inverted Data Output.	
73	GND	Module Ground.	1
74	Tx5+	Transmitter Non-Inverted Data Input.	
75	Tx5-	Transmitter Inverted Data Output.	
76	GND	Module Ground.	1

Notes:

1. QSFP-DD uses common ground (GND) for all signals and power supplies. All are common within the QSFP-DD module, and all module voltages are referenced to this potential unless otherwise noted. Connect these directly to the host board signal common ground plane.

- VccRx, VccRx1, Vcc1, Vcc2, VccTx, and VccTx1 shall be applied concurrently. VccRx, VccRx1, Vcc1, Vcc2, VccTx, and VccTx1 may be internally connected within the module in any combination. The connector Vcc pins are each rated for a maximum current of 1000mA.
- All Vendor-Specific, Reserved, Not Connected, and ePPS (if not used) pins may be terminated with 50Ω to ground on the host. Pad 65 (Not Connected) shall be left unconnected within the module. Vendor-Specific and Reserved pads shall have an impedance to GND that is greater than 10kΩ and less than 100pF.

Module Pad Layout

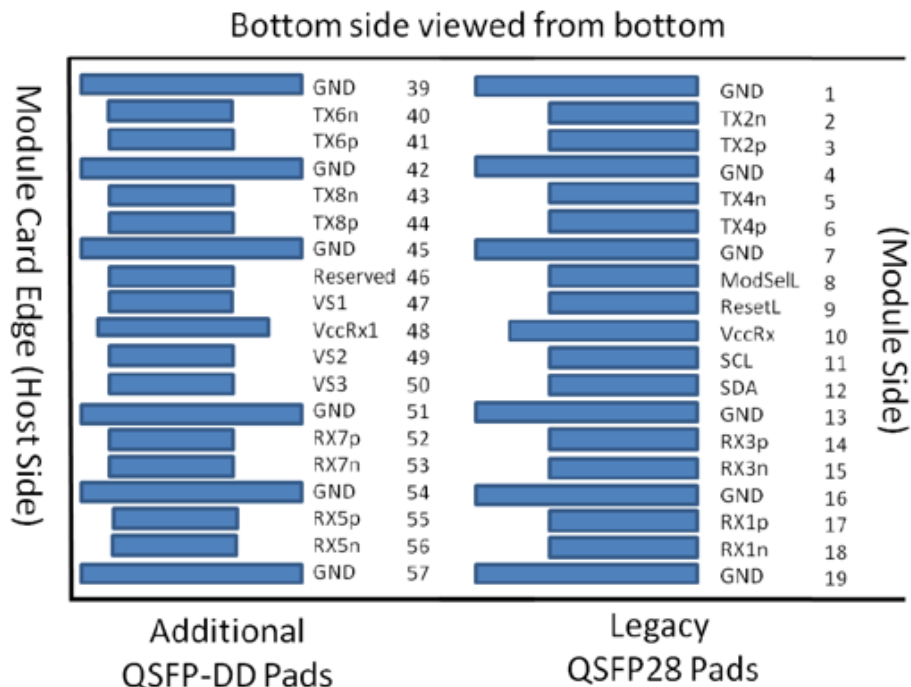
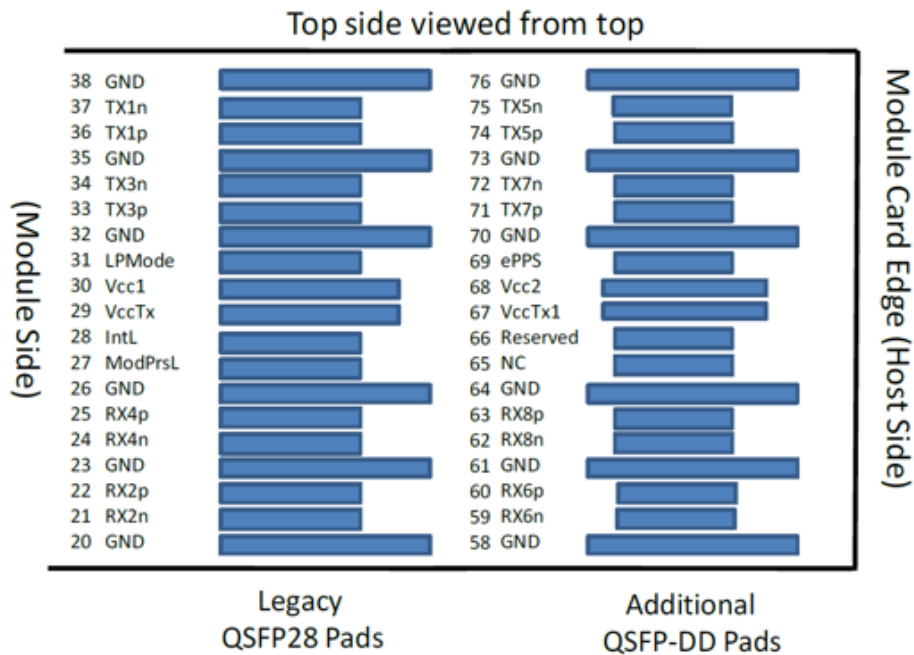

Host Board Power Supply Filter Network

QSFP-DD Hardware Rev 4.0

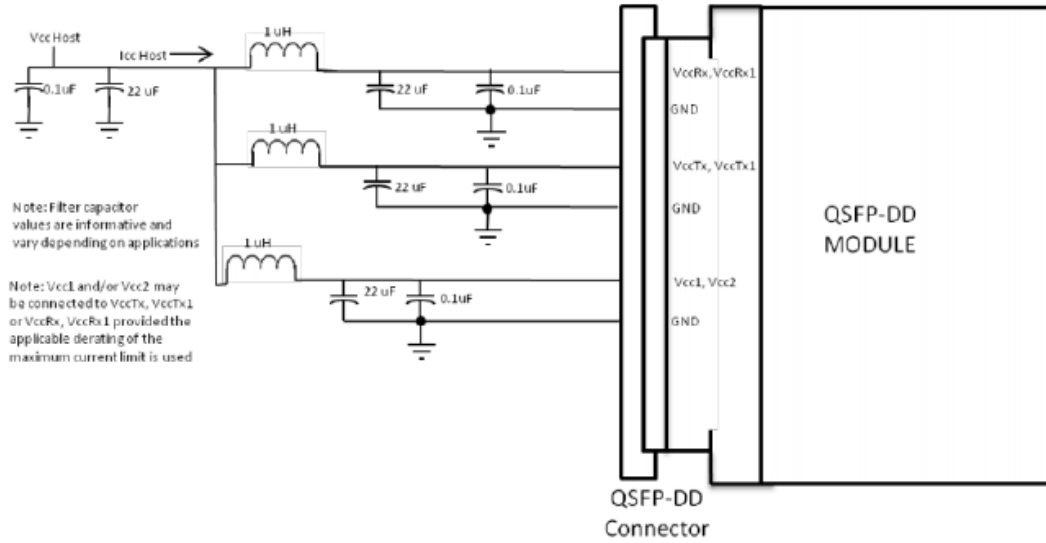

Mechanical Specifications

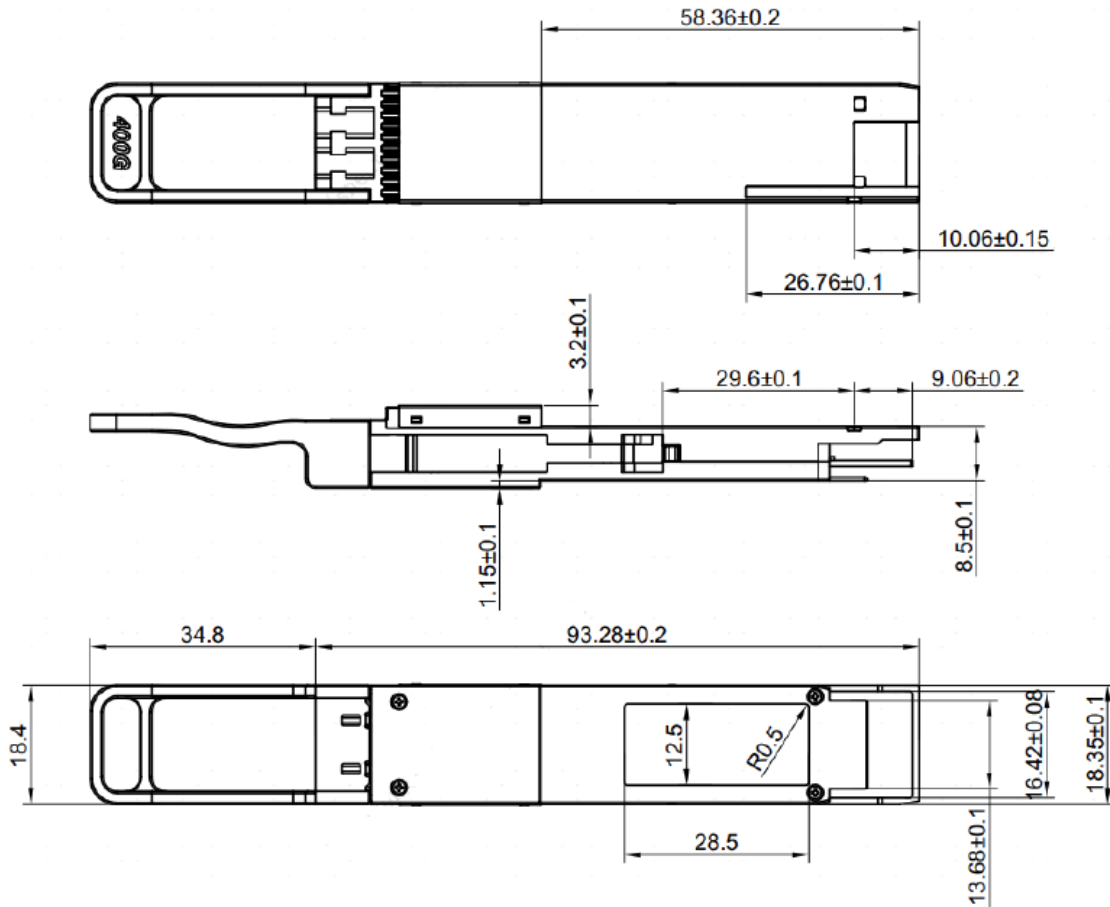

About AddOn Networks

In 1999, AddOn Networks entered the market with a single product. Our founders fulfilled a severe shortage for compatible, cost-effective optical transceivers that compete at the same performance levels as leading OEM manufacturers. Adhering to the idea of redefining service and product quality not previously had in the fiber optic networking industry, AddOn invested resources in solution design, production, fulfillment, and global support.

Combining one of the most extensive and stringent testing processes in the industry, an exceptional free tech support center, and a consistent roll-out of innovative technologies, AddOn has continually set industry standards of quality and reliability throughout its history.

Reliability is the cornerstone of any optical fiber network and is engrained in AddOn's DNA. It has played a key role in nurturing the long-term relationships developed over the years with customers. AddOn remains committed to exceeding industry standards with certifications from ranging from NEBS Level 3 to ISO 9001:2005 with every new development while maintaining the signature reliability of its products.



U.S. Headquarters

Email: sales@addonnetworks.com

Telephone: +1 877.292.1701

Fax: 949.266.9273

Europe Headquarters

Email: salesupportemea@addonnetworks.com

Telephone: +44 1285 842070