

Q28-100GP4-BXU49-40-C1-AO

Cisco® Compatible TAA 100GBase-BX ER1 PAM4 QSFP28 Transceiver Single Lambda (SMF, 1304.58nmTx/1309.14nmRx, 40km, LC, DOM)

Features

- SFF-8636 Rev. 2.10a Compliant
- 100G Lambda MSA 100G-ER1 Specification Compliant
- QSFP28 MSA Compliant
- Bidi LC Receptacles
- Commercial Temperature 0 to 70 Celsius
- Supports 100Gbps with 4x25G Electrical Interface
- Power Dissipation:
- Single 3.3V Power Supply
- RoHS Compliant and Lead Free
- SMF with Inbuild KP4 FEC

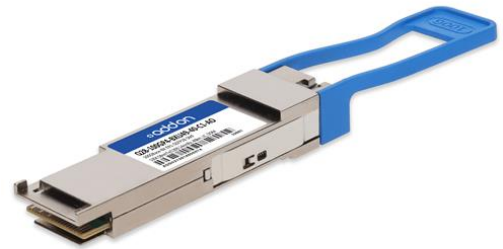

Applications

- Datacenter
- 100GBase Ethernet

Product Description

This Cisco® compatible QSFP28 transceiver provides 100GBase-BX ER1 throughput up to 40km over single-mode fiber (SMF) PAM4 using a wavelength of 1304.58nmTx/1309.14nmRx via an LC connector. This bidirectional unit must be used with another transceiver or network appliance of complementing wavelengths. It can operate at temperatures between 0 and 70C. Our transceiver is built to meet or exceed OEM specifications and is guaranteed to be 100% compatible with Cisco®. It has been programmed, uniquely serialized, and tested for data-traffic and application to ensure that it will initialize and perform identically. All of our transceivers comply with Multi-Source Agreement (MSA) standards to provide seamless network integration. Additional product features include Digital Optical Monitoring (DOM) support which allows access to real-time operating parameters. We stand behind the quality of our products and proudly offer a limited lifetime warranty.

AddOn's transceivers are RoHS compliant and lead-free.

TAA refers to the Trade Agreements Act (19 U.S.C. & 2501-2581), which is intended to foster fair and open international trade. TAA requires that the U.S. Government may acquire only "U.S.-made or designated country end products."



Absolute Maximum Ratings

Parameter	Symbol	Min.	Typ.	Max.	Unit	Notes
Maximum Supply Voltage	Vcc	-0.5		3.6	V	
Storage Temperature	Tstg	-40		85	°C	
Maximum Operating Case Temperature	Tc	-5		75	°C	
Recommended Operating Case Temperature	Tc	0		70	°C	1
Operating Relative Humidity	RH	5		85	%	

Notes:

1. The position of case temperature measurement is shown in the Mechanical Specifications section.
2. Exceeding the Absolute Maximum Ratings table may cause permanent damage to the device. This is just an emphasized rating and does not involve the functional operation of the device that exceeds the specifications of this technical specification under these or other conditions. Long-term operation under Absolute Maximum Ratings will affect the reliability of the device.

Electrical Characteristics

Parameter	Symbol/ Test Point	Min.	Typ.	Max.	Unit	Notes
Power Supply Voltage	Vcc	3.135	3.3	3.465	V	
Power Supply Noise				66	mVp-p	1
Power Consumption				4.5	W	
Total Power Supply Current				1298	mA	
Internal AC Coupling Capacitors			0.1		μF	
Electrical Signal Rate			25.78125		Gbps	
High-Speed Electrical Input Characteristics (Transmitter)						
Differential Pk-Pk Input Voltage Tolerance	TP1a	900			mVp-p	
Differential Input Impedance	TP1	90	100	110	Ω	
Output Rise/Fall Time	TP1a	10			ps	2
Eye Width	TP1a	0.46			UI	3
Eye Height Differential	TP1a	95			mV	3
DC Common-Mode Voltage (Vcm)	TP1	-350		2850	mV	4
High-Speed Electrical Output Characteristics (Receiver)						
Receiver Differential Data Output Load			100		Ω	
Differential Pk-Pk Output Voltage	TP4			900	mVp-p	
Differential Output Impedance	TP4	90	100	110	Ω	
Output Rise/Fall Time	TP4	12			ps	2
Eye Width	TP4	0.57			UI	3

Eye Height Differential	TP4	228			mV	3
DC Common-Mode Voltage (Vcm)	TP4	-350		2850	mV	4

Notes:

1. Power supply noise is defined as the peak-to-peak noise amplitude over the frequency range at the host supply side of the recommended power supply filter with the module and recommended filter in place. Voltage levels including peak-to-peak noise are limited to the recommended operating range of the associated power supply.
2. 20-80%.
3. $1E^{-15}$.
4. Vcm is generated by the host. Specification includes effects of ground offset voltage.

Optical Characteristics

Parameter		Symbol	Min.	Typ.	Max.	Unit	Notes
Optical Signal Rate				53.125		Gbaud	
Fiber Length (9μm SMF)					40	km	1
Transmitter @TP2 Test Point							
Signaling Speed				53.125		Gbaud	
Modulation Format			PAM4				
Center Wavelength		λC	1304.06	1304.58	1305.1	nm	
Side-Mode Suppression Ratio		SMSR	30			dB	
Extinction Ratio		ER	5			dB	
Outer Optical Modulation Amplitude	For TDECQ<1.4dB	TxOMA	4.7		7.9	dBm	
	For 1.4dB≤TDECQ≤3.9dB	TxOMA	3.3+TDECQ			dBm	
Transmit Average		TxAVG	1.7		7.1	dBm	2
Transmitter and Dispersion Eye Closure		TDECQ			3.9	dB	
Launch Power of Off Transmitter Per Lane					-15	dBm	
Relative Intensity Noise		RIN			-136	dB/Hz	
Optical Return Loss Tolerance					15	dB	3
Receiver @TP3 Test Point							
Signaling Speed				53.125		Gbaud	
Center Wavelength		λC	1308.61	1309.14	1309.66	nm	
Damage Threshold		Rxdmg	-2.4			dBm	
Receive Power (OMAouter)		RxOMA			-2.6	dBm	
Average Receive Power		RxAVG	-16		-3.4	dBm	
Receiver Sensitivity (OMAouter)	For TECQ<1.4dB	SenOMA			-13.8	dBm	4
	For 1.4dB≤TECQ≤3.9dB	SenOMA			TECQ-15.2	dBm	4
Stressed Receiver Sensitivity		SRS			-11.3	dBm	
Receiver Reflectance					-26	dB	
LOS Assert		LOSA	-26			dBm	
LOS De-Assert		LOSD			-17	dBm	

Notes:

1. 9μm SMF. The maximum link distance is based on an allocation of 1dB of attenuation and 3dB total connection and splice loss. The loss of a single connection shall not exceed 0.5dB.
2. Average launch power (minimum) is informative and not the principal indicator of signal strength. A transmitter with launch power below this value cannot be compliant; however, a value above this does not ensure compliance.
3. Transmitter reflectance is defined looking into the transmitter.
4. Sensitivity is specified at 2.4×10^{-4} BER with PRBS31Q.

Pin Descriptions

Pin	Logic	Symbol	Name/Description	Plug Sequence	Notes
1		GND	Module Ground.	1	1
2	CML-I	Tx2-	Transmitter Inverted Data Input.	3	
3	CML-I	Tx2+	Transmitter Non-Inverted Data Input.	3	
4		GND	Module Ground.	1	1
5	CML-I	Tx4-	Transmitter Inverted Data Input.	3	
6	CML-I	Tx4+	Transmitter Non-Inverted Data Input.	3	
7		GND	Module Ground.	1	1
8	LVTTL-I	ModSelL	Module Select.	3	
9	LVTTL-I	ResetL	Module Reset.	3	
10		VccRx	+3.3V Receiver Power Supply.	2	2
11	LVC MOS-I/O	SCL	2-Wire Serial Interface Clock.	3	
12	LVC MOS-I/O	SDA	2-Wire Serial Interface Data.	3	
13		GND	Module Ground.	1	1
14	CML-O	Rx3+	Receiver Non-Inverted Data Output.	3	
15	CML-O	Rx3-	Receiver Inverted Data Output.	3	
16		GND	Module Ground.	1	1
17	CML-O	Rx1+	Receiver Non-Inverted Data Output.	3	
18	CML-O	Rx1-	Receiver Inverted Data Output.	3	
19		GND	Module Ground.	1	1
20		GND	Module Ground.	1	1
21	CML-O	Rx2-	Receiver Inverted Data Output.	3	
22	CML-O	Rx2+	Receiver Non-Inverted Data Output.	3	
23		GND	Module Ground.	1	1
24	CML-O	Rx4-	Receiver Inverted Data Output.	3	
25	CML-O	Rx4+	Receiver Non-Inverted Data Output.	3	
26		GND	Module Ground.	1	1
27	LVTTL-O	ModPrsL	Module Present.	3	
28	LVTTL-O	IntL/RxLOSL	Interrupt. Optionally configurable as RxLOSL via the management interface (SFF-8636).	3	
29		VccTx	+3.3V Transmitter Power Supply.	2	2
30		Vcc1	+3.3V Power Supply.	2	2
31	LVTTL-I	LPMoDe/TxDis	Low-Power Mode. Optionally configurable as TxDis via the management interface (SFF-8636).	3	
32		GND	Module Ground.	1	1
33	CML-I	Tx3+	Transmitter Non-Inverted Data Input.	3	
34	CML-I	Tx3-	Transmitter Inverted Data Input.	3	

35		GND	Module Ground.	1	1
36	CML-I	Tx1+	Transmitter Non-Inverted Data Input.	3	
37	CML-I	Tx1-	Transmitter Inverted Data Input.	3	
38		GND	Module Ground.	1	1

Notes:

1. GND is the symbol for signal and supply (power) common for the module. All are common within the module, and all module voltages are referenced to this potential unless otherwise noted. Connect them directly to the host board signal-common ground plane.
2. VccRx, Vcc1, and VccTx are the receiving and transmission power suppliers and are applied concurrently. VccRx, Vcc1, and VccTx are internally connected within the module in any combination. Vcc contacts in SFF-8662 and SFF-8672 each have a steady state current rating of 1A.

QSFP28 Transceiver Electrical Pad Layout

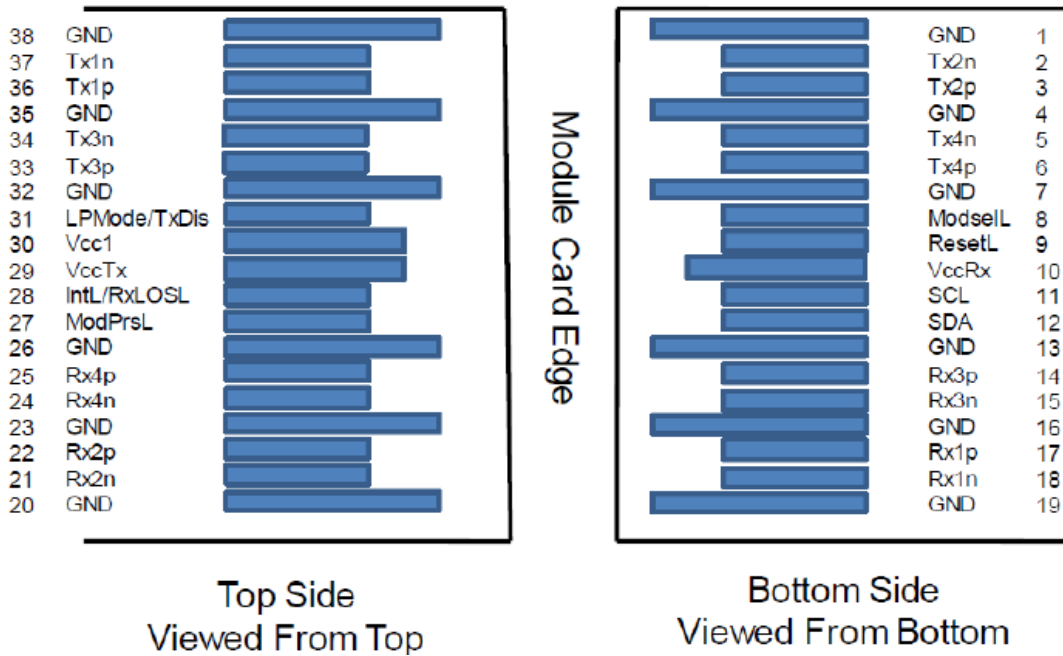

Host Board Power Supply Filter

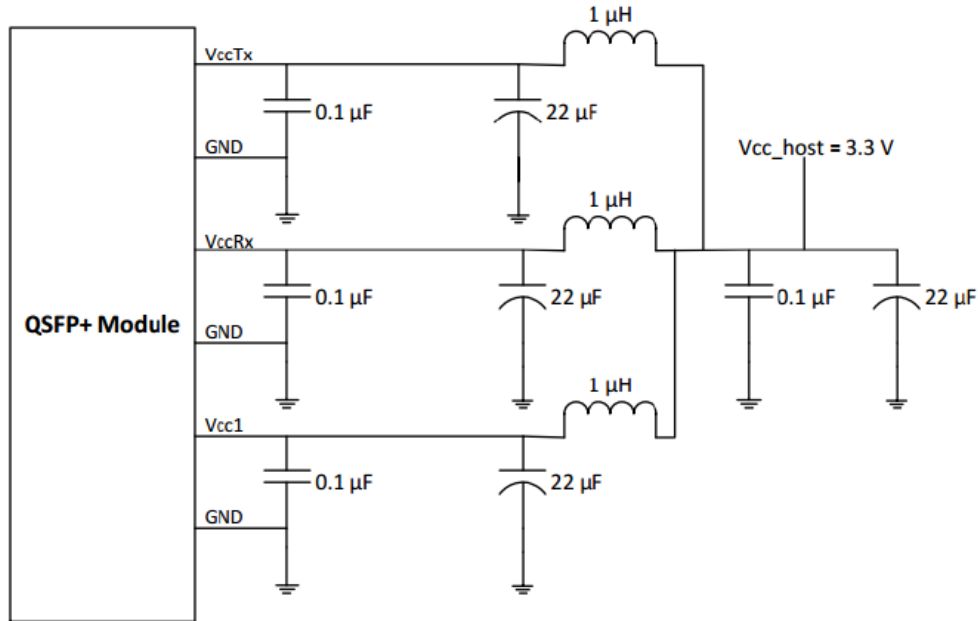

Notes:

1. During power transient events, the host should ensure that any neighboring modules sharing the same supply stay within their specified supply voltage limits. The host should also ensure that the intrinsic noise of the power rail is filtered in order to guarantee the correct operation of the optical modules.

Transceiver Block Diagram

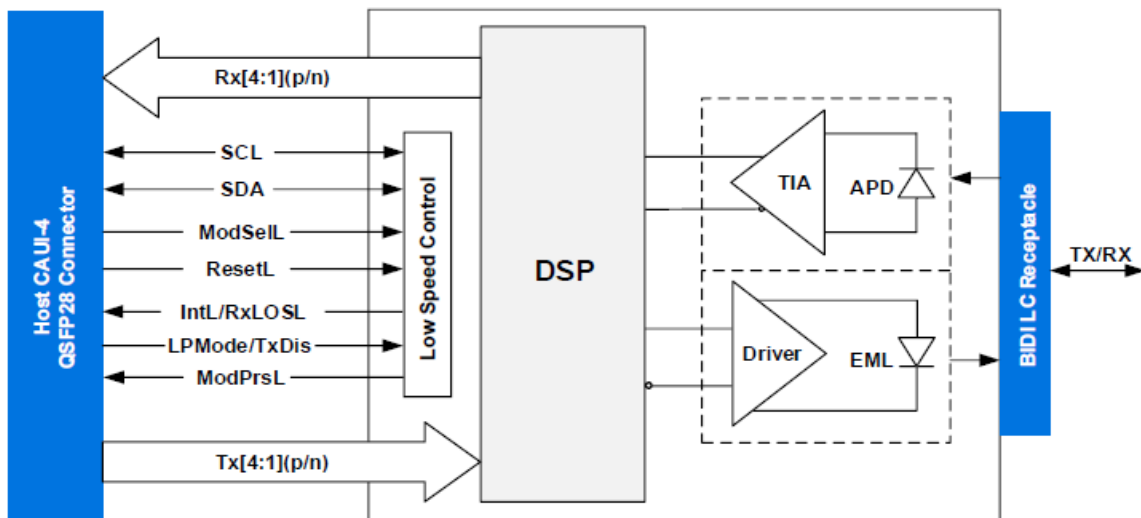

Notes:

1. The transmitter path of the transceiver contains a 4x25Gbps CAUI-4 electrical input, integrated electrical multiplexer, EML driver, EML laser, and diagnostic monitor. The integrated electrical multiplexer converts 4 channels of 25Gbps (NRZ) electrical input data to 1 channel of 100Gbps (PAM4) optical signal.

- The receiver path of the transceiver contains an APD, trans-impedance amplifier (TIA), integrated de-multiplexer, and 4x25Gbps CAUI-4 compliant electrical output block. The integrated de-multiplexer converts 1 channel of 100Gbps (PAM4) optical signal to 4 channels of 25Gbps (NRZ) electrical output data.

Application Reference Diagram

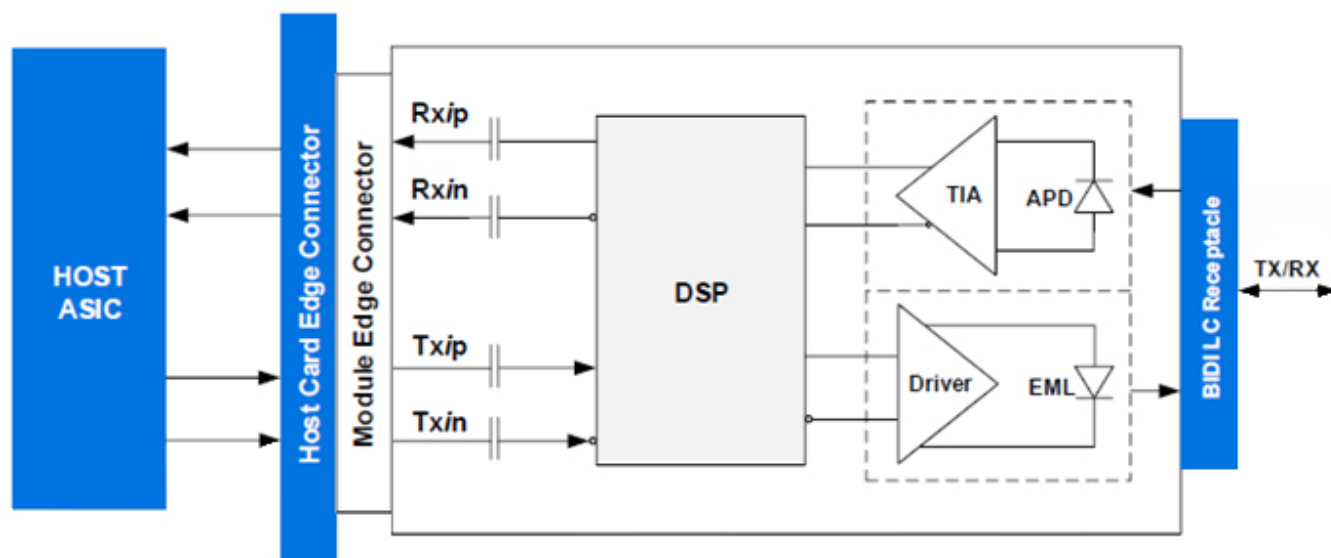

Notes:

- Only one channel "i" (i = 1, 2, 3, 4) shown for simplicity.
- The interface between the QSFP28 module and the ASIC/SerDes is shown above. The high-speed signal lines are internally AC coupled, and the electrical inputs are internally terminated to 100Ω differential. All transmitter and receiver electrical channels are compliant to CAUI-4 specification per IEEE 802.3cd.
- The module has the following low-speed signals for control and status: ModSell, ResetL, LPMoDe/TxDis, ModPrsL, and IntL/RxLOSL. In addition, there is an industry-standard 2-wire serial interface scaled for 3.3V LVTTTL. The definition of control signal interface and the registers of the serial interface memory are further defined in this document.
- Exposure to current surges and overvoltage events can cause immediate damage to the transceiver module. Observe the precautions for normal operation of electrostatic discharge-sensitive equipment. Attention should also be taken to restrict exposure to the conditions defined in the Absolute Maximum Ratings. Optical connectors will be exposed if the port plug is not inserted, so always pay attention to protection. Each module is equipped with a port guard plug to protect the optical ports. The protective plug shall always be in place whenever the optical fiber is not inserted. Before inserting the optical fiber, it is recommended to clean the end of the optical fiber connector to avoid contamination of the module optical port due to a dirty connector. If contamination occurs, use standard LC port cleaning methods.

Mechanical Specifications

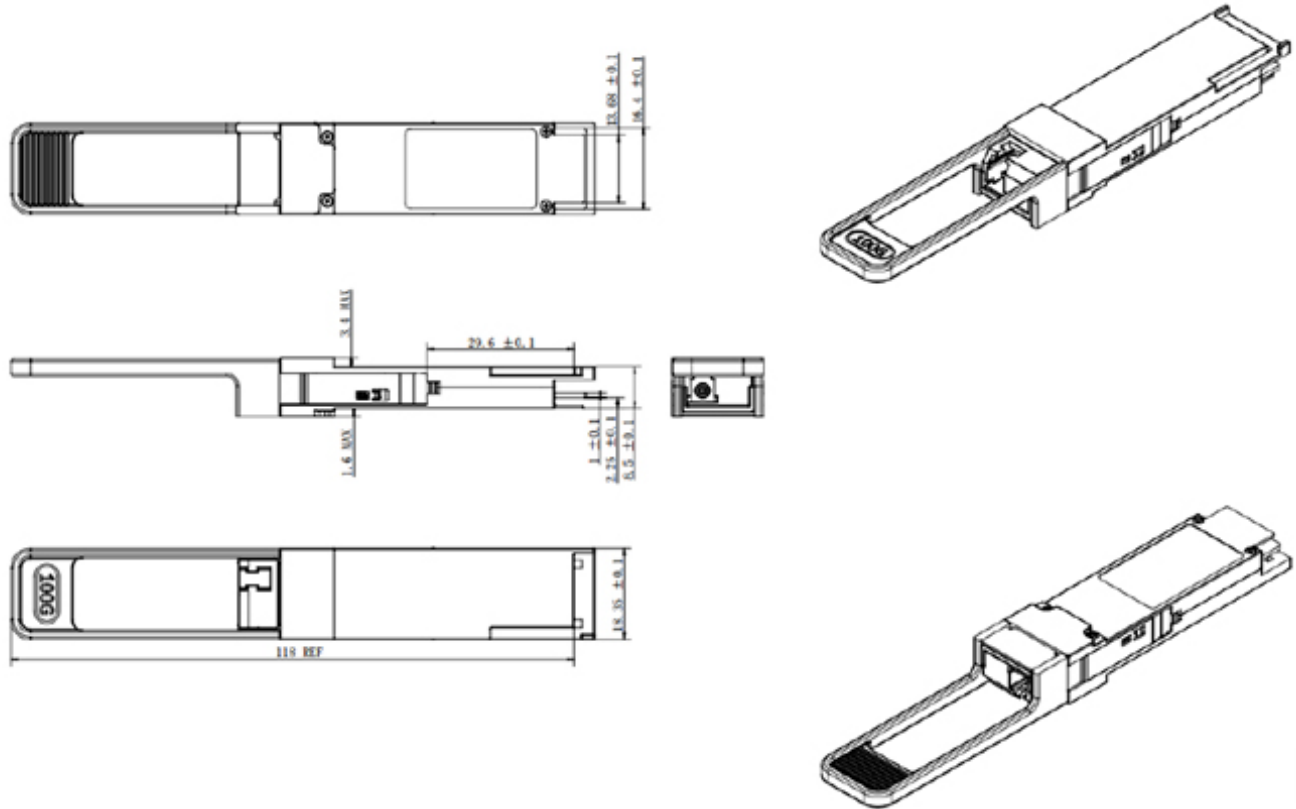

Notes:

1. All dimensions are in mm.
2. Unmarked tolerance complies with GB/T1804-M.

Case Temperature Measurement Point

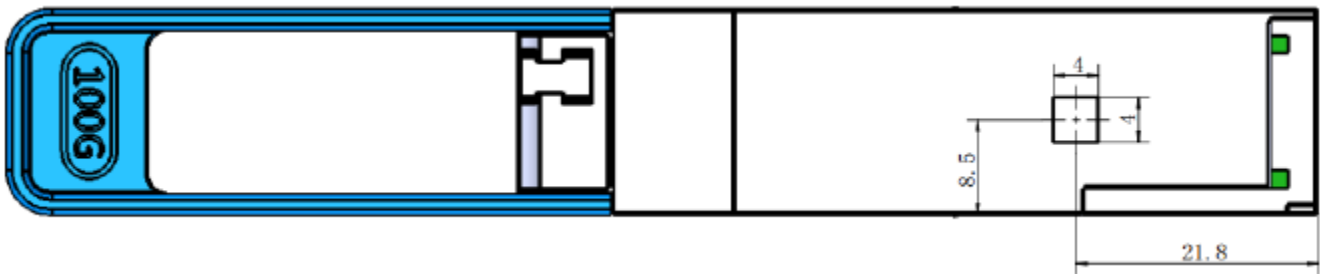

Notes:

1. All dimensions are in mm.
2. The above picture shows the location of the hottest spot for measuring module case temperature. In addition, the Digital Diagnostic Monitoring (DDM) temperature is also calibrated to this spot.

Module Optical Interface (Looking into the Optical Port)



About AddOn Networks

In 1999, AddOn Networks entered the market with a single product. Our founders fulfilled a severe shortage for compatible, cost-effective optical transceivers that compete at the same performance levels as leading OEM manufacturers. Adhering to the idea of redefining service and product quality not previously had in the fiber optic networking industry, AddOn invested resources in solution design, production, fulfillment, and global support.

Combining one of the most extensive and stringent testing processes in the industry, an exceptional free tech support center, and a consistent roll-out of innovative technologies, AddOn has continually set industry standards of quality and reliability throughout its history.

Reliability is the cornerstone of any optical fiber network and is ingrained in AddOn's DNA. It has played a key role in nurturing the long-term relationships developed over the years with customers. AddOn remains committed to exceeding industry standards with certifications ranging from NEBS Level 3 to ISO 9001:2015 with every new development while maintaining the signature reliability of its products.



U.S. Headquarters

Email: sales@addonnetworks.com

Telephone: +1 877.292.1701

Fax: 949.266.9273

Europe Headquarters

Email: salesemea@addonnetworks.com

Telephone: +44 1285 842070