

QSFP28-100GB-PSM4-NF-J-AO

Juniper Networks® Compatible TAA 100GBase-PSM4 QSFP28 Transceiver (SMF, 1310nm, 2km, MPO, DOM, No FEC)

Features

- Compliant to IEEE 802.3bm
- Compliant with MSA 100G PSM4 Specifications
- 4 Parallel Lanes Design
- Single 3.3V Power Supply
- 4-Channel PIN Photo Detector
- Up to 25.78125Gbps Per Channel Data Links
- Class 1 Laser Safety Certified
- Up to 2km on SMF with No FEC
- RoHS Compliant and Lead-Free
- Commercial Temperature: 0 to 70 Celsius



Applications

- 100GBase Ethernet

Product Description

This Juniper Networks® QSFP28 transceiver provides 100GBase-PSM4 throughput up to 2km over single-mode fiber (SMF) using a wavelength of 1310nm via an MPO connector. It is guaranteed to be 100% compatible with the equivalent Juniper Networks® transceiver. This easy to install, hot swappable transceiver has been programmed, uniquely serialized and data-traffic and application tested to ensure that it will initialize and perform identically. Digital optical monitoring (DOM) support is also present to allow access to real-time operating parameters. This transceiver is Trade Agreements Act (TAA) compliant. We stand behind the quality of our products and proudly offer a limited lifetime warranty.

AddOn's transceivers are RoHS compliant and lead-free.

TAA refers to the Trade Agreements Act (19 U.S.C. & 2501-2581), which is intended to foster fair and open international trade. TAA requires that the U.S. Government may acquire only "U.S. – made or designated country end products."



Absolute Maximum Ratings

Parameter	Symbol	Min.	Typ.	Max.	Unit	Notes
Power Supply Voltage	V _{CC}	-0.5		4	V	
Storage Temperature	T _{stg}	-40		85	°C	
Case Operating Temperature	T _c	0	25	70	°C	
Relative Humidity	RH	5		95	%	
Data Rate	BR		25.78125		Gbps	

Electrical Characteristics

Parameter	Symbol	Min.	Typ.	Max.	Unit	Notes
Power Supply Voltage	V _{CC}	3.135	3.3	3.465	V	
Power Supply Current	I _{CC}			1060	mA	
Power Dissipation	P _{DISS}			3500	W	
Transmitter						
Input Differential Impedance	Z _{IN}	90	100	110	Ω	
Differential Data Input Swing	V _{IN,pp}	190		700	mVp-p	
AC Common-Mode Input Voltage Tolerance		15			mV	
Receiver						
Output Differential Impedance	Z _{OUT}	90	100	110	Ω	
Differential Data Output Swing	V _{OUT,pp}	300		850	mVp-p	1
AC Common-Mode Output Voltage		12		7.5	ps	
Single-Ended Output Voltage		-0.3		4		

Notes:

1. Internally AC coupled but requires an external 100Ω differential load termination.

Optical Characteristics

Parameter	Symbol	Min.	Typ.	Max.	Unit	Notes
Transmitter						
Launch Optical Power Per Lane	Po	-4.5		4	dBm	1
Side-Mode Suppression Ratio	SMSR	30			dB	
Center Wavelength	λ	1295	1310	1325	nm	
Extinction Ratio	ER	3.5			dB	2
Optical Return Loss Tolerance	ORLT			20	dB	
POUT @Tx_Disable Asserted	Poff			-30	dBm	1
Transmitter Eye Mask Definition	{X1, X2, X3, Y1, Y2, Y3} {0.31, 0.4, 0.45, 0.34, 0.38, 0.4}					
Receiver						
Center Wavelength	λ_C	1295		1325	nm	
Average Receive Power Per Lane	P1	-7.5		2.0	dBm	
Receiver Sensitivity Per Lane	S			-7.5	dBm	3
Receiver Overload Per Channel	POL	2.0			dBm	3
Damage Threshold	Pdamage	3.0			dBm	
LOS De-Assert	LOSD			-12.5	dBm	
LOS Assert	LOSA	-24			dBm	
LOS Hysteresis		0.5			dB	

Notes:

1. The optical power is launched into the SMF.
2. Measured with a PRBS $2^{31}-1$ test pattern @25.78125Gbps.
3. Measured with PRBS $2^{31}-1$ test pattern, @25.78125Gbps per lane, and BER= 1×10^{-12} .

Pin Descriptions

Pin	Symbol	Name/Description	Notes
1	GND	Transmitter Ground (Common with Receiver Ground).	1
2	Tx2-	Transmitter Inverted Data Input.	
3	Tx2+	Transmitter Non-Inverted Data Input.	
4	GND	Transmitter Ground (Common with Receiver Ground).	1
5	Tx4-	Transmitter Inverted Data Input.	
6	Tx4+	Transmitter Non-Inverted Data Input.	
7	GND	Transmitter Ground (Common with Receiver Ground).	1
8	ModSelL	Module Select.	2
9	ResetL	Module Reset.	2
10	VccRx	+3.3V Receiver Power Supply.	
11	SCL	2-Wire Serial Interface Clock.	2
12	SDA	2-Wire Serial Interface Data.	2
13	GND	Transmitter Ground (Common with Receiver Ground).	1
14	Rx3+	Receiver Non-Inverted Data Output.	
15	Rx3-	Receiver Inverted Data Output.	
16	GND	Transmitter Ground (Common with Receiver Ground).	1
17	Rx1+	Receiver Non-Inverted Data Output.	
18	Rx1-	Receiver Inverted Data Output.	
19	GND	Transmitter Ground (Common with Receiver Ground).	1
20	GND	Transmitter Ground (Common with Receiver Ground).	1
21	Rx2-	Receiver Inverted Data Output.	
22	Rx2+	Receiver Non-Inverted Data Output.	
23	GND	Transmitter Ground (Common with Receiver Ground).	1
24	Rx4-	Receiver Inverted Data Output.	1
25	Rx4+	Receiver Non-Inverted Data Output.	
26	GND	Transmitter Ground (Common with Receiver Ground).	1
27	ModPrsL	Module Present.	
28	IntL	Interrupt.	2
29	VccTx	+3.3V Transmitter Power Supply.	
30	Vcc1	+3.3V Power Supply.	
31	LPMoDe	Low-Power Mode.	2
32	GND	Transmitter Ground (Common with Receiver Ground).	1
33	Tx3+	Transmitter Non-Inverted Data Input.	
34	Tx3-	Transmitter Inverted Data Output.	
35	GND	Transmitter Ground (Common with Receiver Ground).	1
36	Tx1+	Transmitter Non-Inverted Data Input.	

37	Tx1-	Transmitter Inverted Data Input.	
38	GND	Transmitter Ground (Common with Receiver Ground).	1

Notes:

1. The module signal grounds are isolated from the module case.
2. This is open collector/drain output that, on the host board, requires a 4.7kΩ to 10kΩ pull-up resistor to the Host_Vcc.

Electrical Pin-Out Details

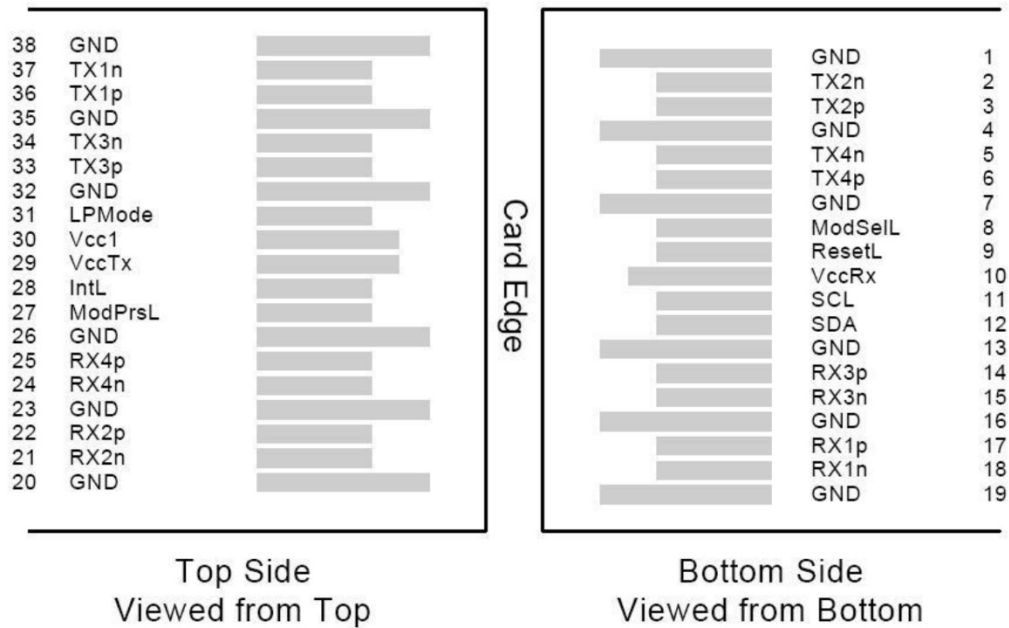

Recommended Host Board Power Supply Filter Network

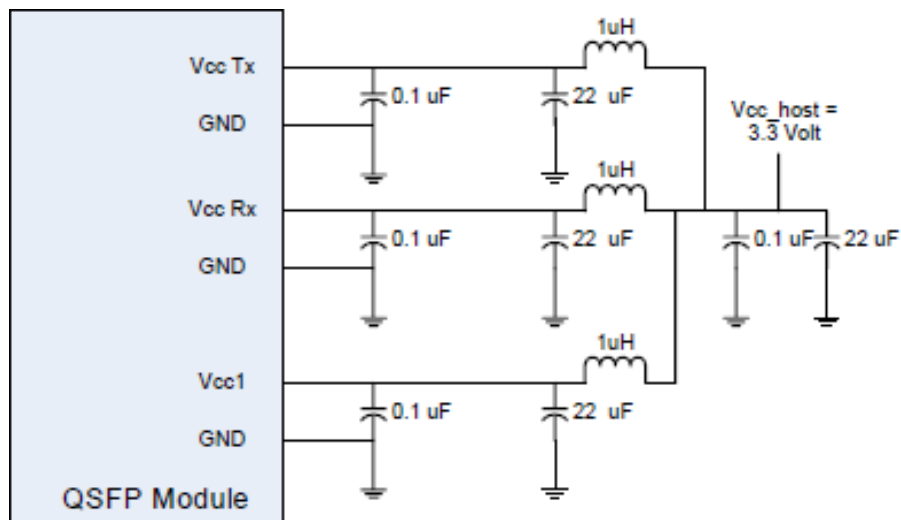

Transceiver Interface Block Diagram

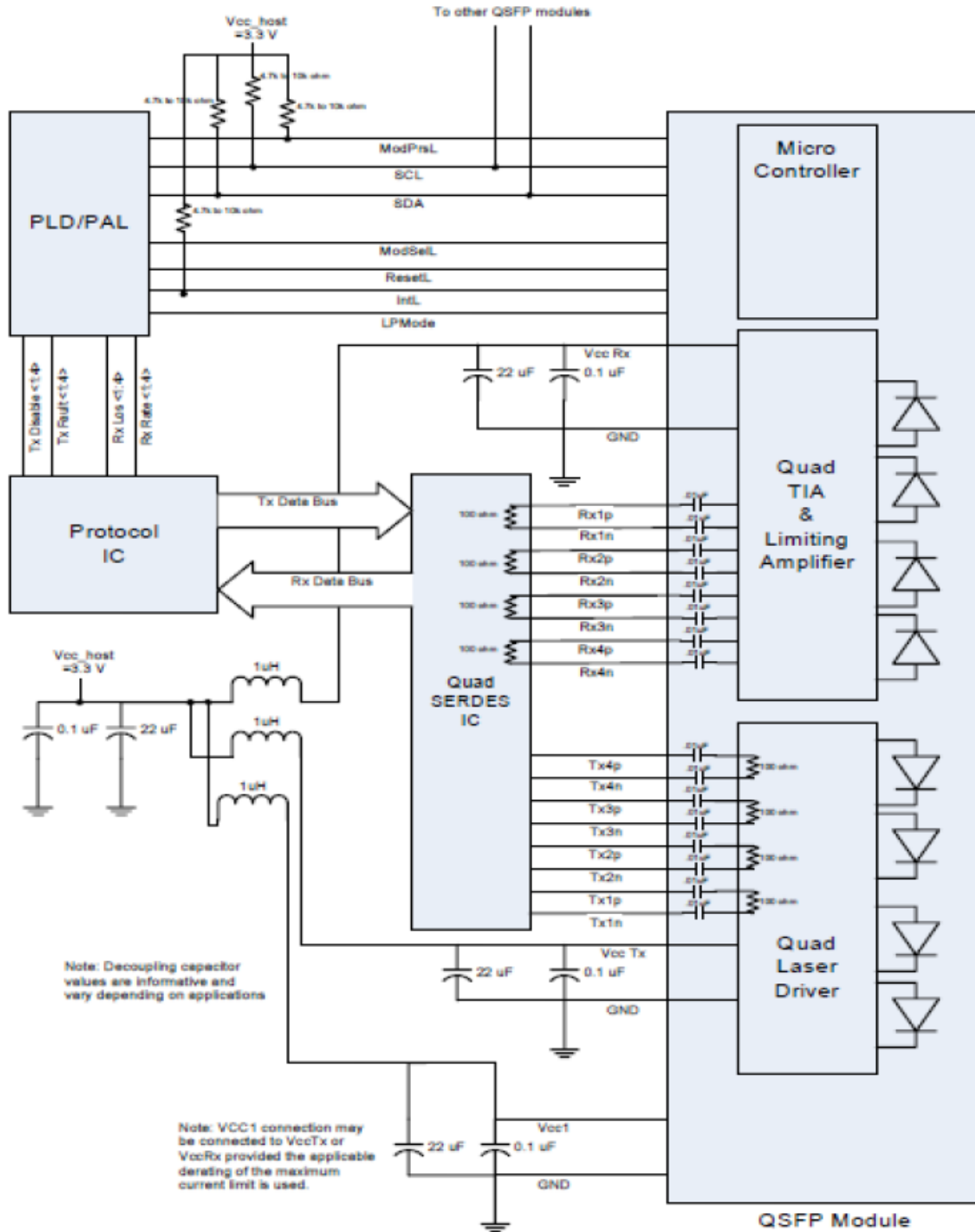

Mechanical Specifications

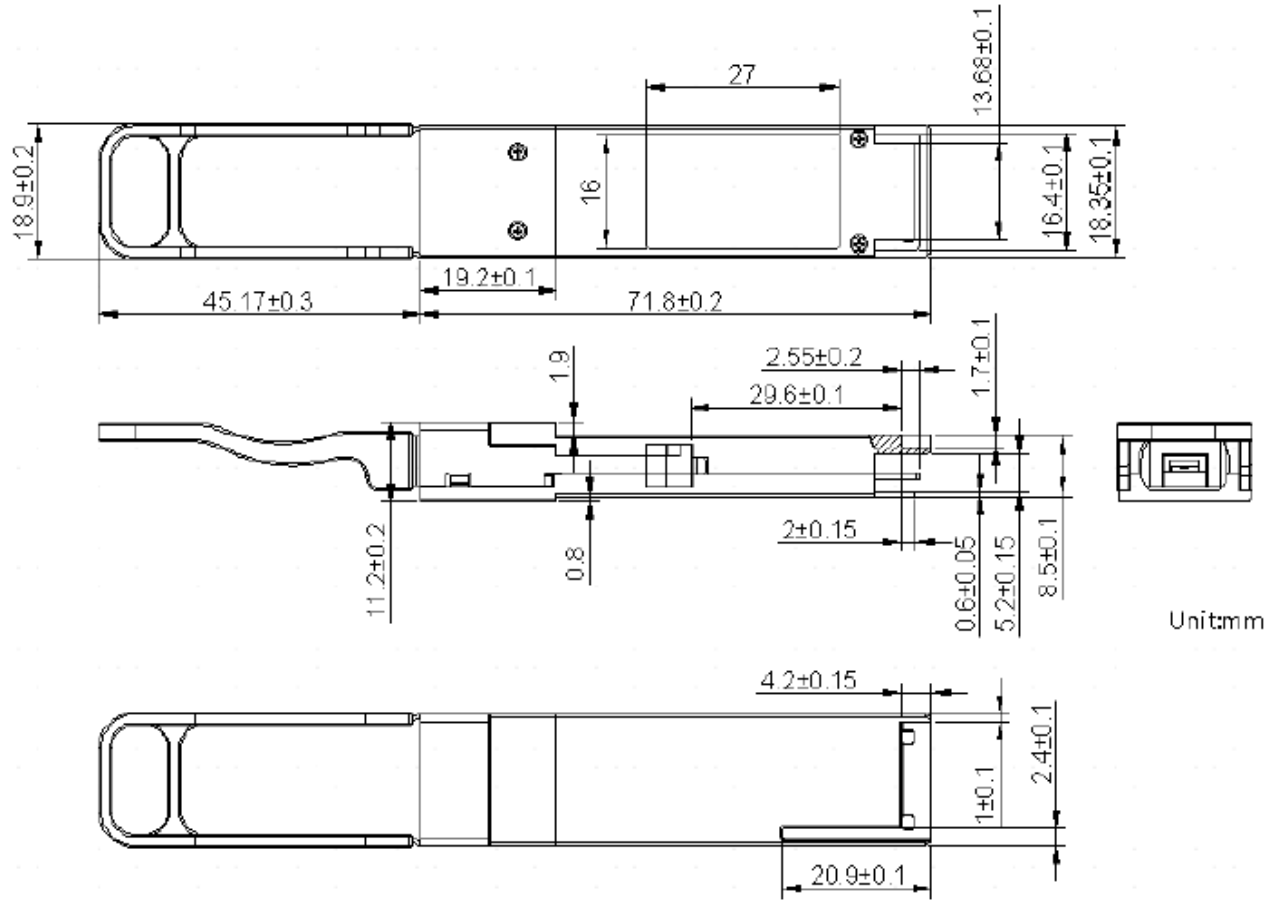

About AddOn Networks

In 1999, AddOn Networks entered the market with a single product. Our founders fulfilled a severe shortage for compatible, cost-effective optical transceivers that compete at the same performance levels as leading OEM manufacturers. Adhering to the idea of redefining service and product quality not previously had in the fiber optic networking industry, AddOn invested resources in solution design, production, fulfillment, and global support.

Combining one of the most extensive and stringent testing processes in the industry, an exceptional free tech support center, and a consistent roll-out of innovative technologies, AddOn has continually set industry standards of quality and reliability throughout its history.

Reliability is the cornerstone of any optical fiber network and is engrained in AddOn's DNA. It has played a key role in nurturing the long-term relationships developed over the years with customers. AddOn remains committed to exceeding industry standards with certifications from ranging from NEBS Level 3 to ISO 9001:2005 with every new development while maintaining the signature reliability of its products.



U.S. Headquarters

Email: sales@addonnetworks.com

Telephone: +1 877.292.1701

Fax: 949.266.9273

Europe Headquarters

Email: salesupportemea@addonnetworks.com

Telephone: +44 1285 842070