

## SFP-1GB-CW-59-200-CN2-AO

Ciena® Compatible TAA 1000Base-CWDM SFP Transceiver (SMF, 1590nm, 200km, LC, DOM)

### Features

- SFF-8472 Compliance
- Operating Data Rate up to 1.25Gbps
- Duplex LC Connector
- Single-mode Fiber
- Commercial Temperature 0 to 70 Celsius
- CWDM DFB LD Transmitter
- Metal with Lower EMI
- Hot Pluggable
- RoHS Compliant and Lead Free
- Excellent ESD Protection



### Applications

- 1x Fibre Channel
- Ethernet over CWDM
- Access, Metro and Enterprise

### Product Description

This Ciena® SFP transceiver provides 1000Base-CWDM throughput up to 200km over single-mode fiber (SMF) using a wavelength of 1590nm via an LC connector. It is guaranteed to be 100% compatible with the equivalent Ciena® transceiver. This easy to install, hot swappable transceiver has been programmed, uniquely serialized and data-traffic and application tested to ensure that it will initialize and perform identically. Digital optical monitoring (DOM) support is also present to allow access to real-time operating parameters. This transceiver is Trade Agreements Act (TAA) compliant. We stand behind the quality of our products and proudly offer a limited lifetime warranty.

AddOn's transceivers are RoHS compliant and lead-free.

TAA refers to the Trade Agreements Act (19 U.S.C. & 2501-2581), which is intended to foster fair and open international trade. TAA requires that the U.S. Government may acquire only "U.S. – made or designated country end products."



## Absolute Maximum Ratings

Parameter	Symbol	Min.	Typ.	Max.	Unit
Maximum Supply Voltage	Vcc	-0.5		3.6	V
Power Supply Voltage	Vcc	3.15	3.3	3.45	V
Power Supply Current	Icc			300	mA
Storage Temperature	Tstg	-40		85	°C
Operating Case Temperature	Tc	0		70	°C
Operating Relative Humidity				95	%
Data Rate	GBE		1.25		Gbps
Data Rate	FC		1.063		Gbps

### Notes:

1. Exceeding any one of these values may destroy the device immediately.

## Electrical Characteristics

Parameter	Symbol	Min.	Typ.	Max.	Unit	Notes
<b>Transmitter</b>						
LVPECL Differential Inputs	VIN	400		2000	mVp-p	1
Input Differential Impedance	ZIN	85	100	115	Ω	2
Tx_Disable	Disable	2		Vcc+0.3	V	
	Enable	0		0.8	V	
Tx_Fault	Fault	2		Vcc+0.3	V	
	Normal	0		0.8	V	
<b>Receiver</b>						
LVPECL Differential Outputs	VOUT	400		2000	mVp-p	3
Output Differential Impedance	ZOUT	85	100	115	Ω	
Tx_Disable Assert Time	T_off			10	us	
Rx_LOS	LOS	2		Vcc+0.3	V	
	Normal	0		0.8	V	
MOD_DEF(0.2)	VOH	2.5			V	4
	VOL	0		0.5	V	4

### Notes:

1. LVPECL Logic. Internally AC Coupled Inputs.
2. RIN>100kΩ @ DC.
3. LVPECL Logic. Internally AC Coupled Outputs.
4. With Serial ID.

## Optical Characteristics

Parameter	Symbol	Min.	Typ.	Max.	Unit	Notes
Link Budget		41			dB	
Data Rate			1.25		Gbps	
<b>Transmitter</b>						
Center Wavelength	$\lambda_C$	1584	1590	1597.5	nm	
Spectral Width (RMS)	$\Delta\lambda$			1	nm	
Average Output Power	POUT	4		7	dBm	1
Side-Mode Suppression Ratio	SMSR	30			dB	
Extinction Ratio	ER	8.2			dB	
Rise/Fall Time (20-80%)	$T_r/T_f$			0.26	ns	
Total Jitter	TJ			0.43	UI	2
Output Optical Eye	Compliant with IEEE 802.3					2
POUT @ Tx_Disable Asserted	POUT			-45	dBm	
<b>Receiver</b>						
Center Wavelength	$\lambda_C$	1260		1620	nm	
Receiver Sensitivity	Pmin			-37	dBm	3
Receiver Overload	Pmax	-10			dBm	
LOS De-Assert	LOSD			-38	dBm	
LOS Assert	LOSA	-50			dBm	
LOS Hysteresis	LOSH	0.5			dB	

### Notes:

1. Output power is measured by coupling into a 9/125 $\mu$ m single-mode fiber.
2. Filtered. Measured with a PRBS 2<sup>7</sup>-1 test pattern @1250Mbps.
3. Minimum average optical power is measured at BER<1E<sup>-12</sup> with 2<sup>7</sup>-1 PRBS and ER=9dB.

## Pin Descriptions

Pin	Symbol	Name/Description	Plug Sequence	Notes
1	VeeT	Transmitter Ground.	1	5
2	Tx_Fault	Transmitter Fault Indication.	3	1
3	Tx_Disable	Transmitter Disable. Module disables on “high” or “open.”	3	2
4	MOD-DEF2	Module Definition 2. 2-Wire Serial ID Interface Data.	3	3
5	MOD-DEF1	Module Definition 1. 2-Wire Serial ID Interface Clock.	3	3
6	MOD-DEF0	Module Definition 0. Grounded within the module.	3	3
7	Rate Select	Not Connected. Function Not Available.	3	
8	LOS	Loss of Signal.	3	4
9	VeeR	Receiver Ground.	1	5
10	VeeR	Receiver Ground.	1	5
11	VeeR	Receiver Ground.	1	5
12	RD-	Inverted Received Data Out.	3	6
13	RD+	Received Data Out.	3	7
14	VeeR	Receiver Ground.	1	5
15	VccR	Receiver Power. 3.3±5%.	2	7
16	VccT	Transmitter Power. 3.3±5%.	2	7
17	VeeT	Transmitter Ground.	1	5
18	TD+	Transmit Data In.	3	8
19	TD-	Inverted Transmit Data In.	3	8
20	VeeT	Transmitter Ground.	1	5

### Notes:

1. Tx\_Fault is an open collector/drain output which should be pulled up with a 4.7kΩ to 10kΩ resistor on the host board. Pull-up voltage is between 2.0V and VccT/R+0.3V. When “high,” output indicates a laser fault of some kind. “Low” indicates normal operation. In the “low” state, the output will be pulled to <0.8V.
2. Tx\_Disable is an input that is used to shut down the transmitter optical output. It is pulled up within the module with a 4.7kΩ to 10kΩ resistor. Its states are:
  - Low (0V-0.8V): Transmitter On
  - (>0.8V, <2.0V): Undefined
  - High (2.0V-3.465V): Transmitter Disabled
  - Open: Transmitter Disabled.
3. MOD-DEF0, 1, and 2. These are the module definition pins. They should be pulled up with a 4.7kΩ to 10kΩ resistor on the host board. The pull-up voltage shall be VccT or VccR.
  - MOD-DEF0 is grounded by the module to indicate that the module is present.
  - MOD-DEF1 is the clock line of the 2-Wire Serial Interface for Serial ID.
  - MOD-DEF2 is the data line of the 2-Wire Serial Interface for Serial ID.
4. LOS (Loss of Signal) is an open collector/drain output which should be pulled up with a 4.7kΩ to 10kΩ

resistor. Pull-up voltage is between 2.0V and  $V_{ccT}/R+0.3V$ . When “high,” this output indicates that the received optical power is below the worst-case receiver sensitivity (as defined by the standard in use). “Low” indicates normal operation. In the “low” state, the output will be pulled to  $<0.8V$ .

5. VeeR and VeeT may be internally connected within the SFP module.
6. RD±. These are the differential receiver outputs. They are AC coupled 100 differential lines which should be terminated with 100 (differential) at the user SERDES. The AC coupling is done inside the module and is thus not required on the host board. The voltage swing on these lines will be between 400mV to 2000mV differential (200mV to 1000mV, single-ended) when properly terminated.
7. VccR and VccT are the receiver and transmitter power supplies. They are defined as  $3.3V\pm5\%$  at the SFP connector pin. Maximum supply current is 300mA. Recommended host board power supply filtering is shown below. Inductors with DC resistance of  $<1\Omega$  should be used in order to maintain the required voltage at the SFP input pin with 3.3V supply voltage. When the recommended supply-filtering network is used, hot plugging of the SFP transceiver module will result in an inrush current of no more than 30mA greater than the steady state value. VccR and VccT may be internally connected within the SFP transceiver module.
8. TD±. These are the differential transmitter inputs. They are AC coupled, differential lines with 100 differential terminations inside the module. The AC coupling is done inside the module and is thus not required on the host board. The inputs will accept differential swings of 400mV to 2000mV (200mV to 1000mV, single-ended).

### Electrical Pin-Out Details

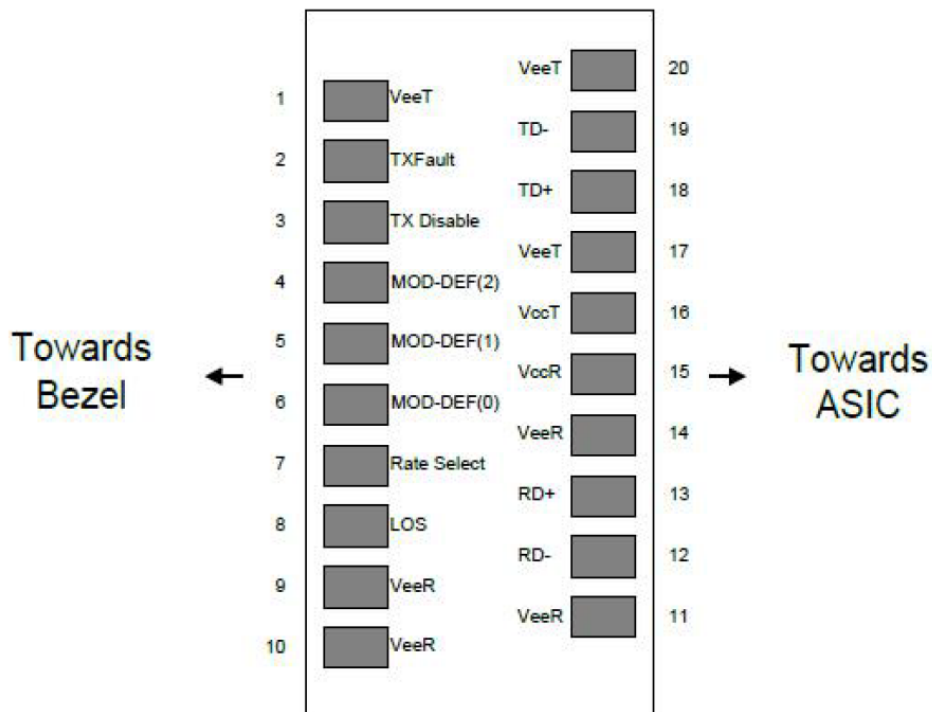

## Recommended Circuit Schematic

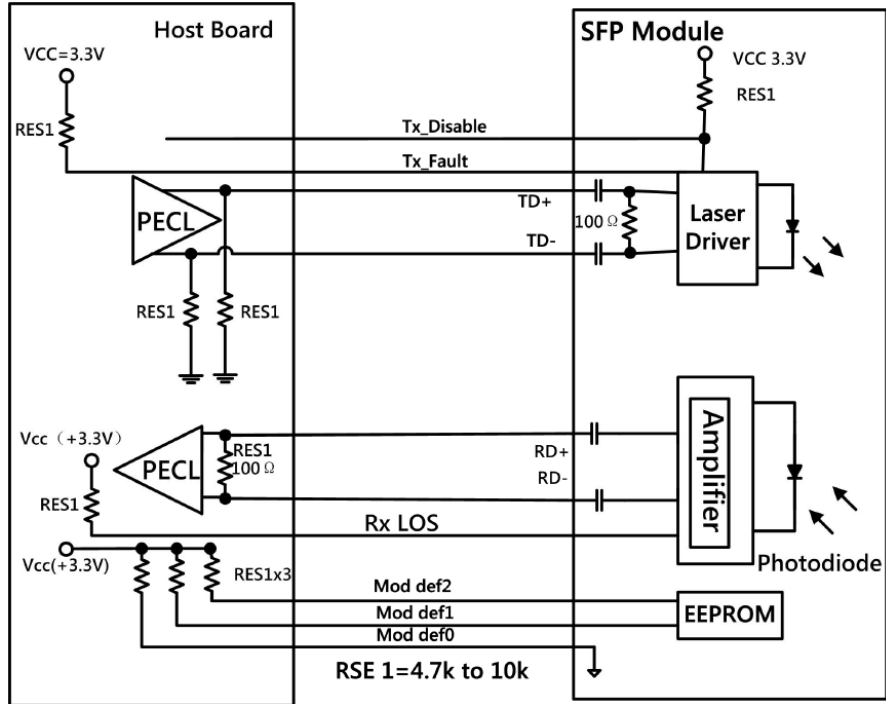

## EEPROM Information

The serial interface uses the 2-wire serial CMOS EEPROM protocol defined for the ATMEL AT24c02/04 family of components. When the serial protocol is activated, the host generates the serial clock signal (SCL). The positive edge clocks data into those segments of the EEPROM that are not write-protected within the SFP+ transceiver. The negative edge clocks data from the SFP+ transceiver. The serial data signal (SDA) is bi-directional for serial data transfer. The host uses SDA in conjunction with SCL to mark the start and end of serial protocol activation. The memories are organized as a series of 8-bit data words that can be addressed individually or sequentially.

The module provides diagnostic information about the present operation conditions. The transceiver generates this diagnostic data by digitization of the internal analog signals. Calibration and alarm/warning threshold data is written during device manufacture. Received power monitoring, transmitted power monitoring, bias current monitoring, supply voltage monitoring, and temperature monitoring are all implemented. If the module is defined as externally calibrated, the diagnostic data are raw A/D values and must be converted to real-world units using calibration constants stored in EEPROM locations 56-95 at the wire serial bus address A2h. The digital diagnostic memory map-specific data field is defined as the following. For detailed EEPROM information, please refer to SFF-8472 Rev. 10.2.

2 wire address 1010000X(A0h)

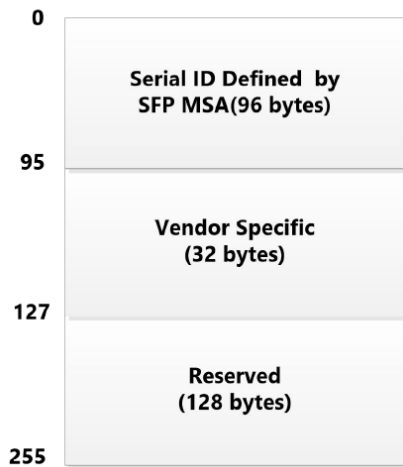

2 wire address 1010000X (A2h)

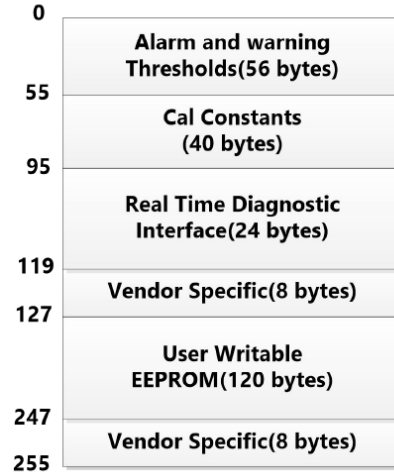

Mechanical Specifications

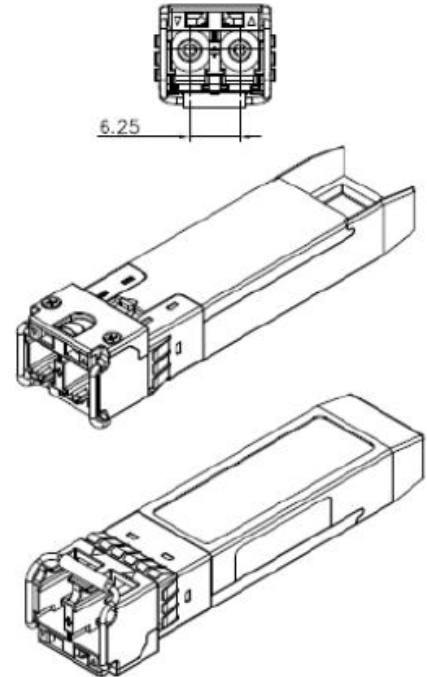
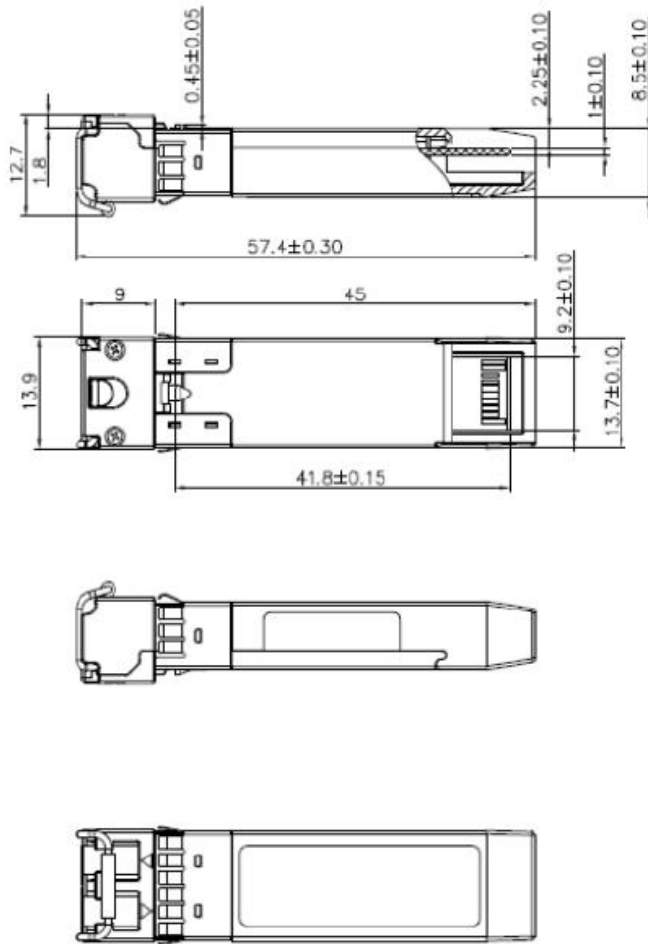

Unremarked tolerances  $\pm 0.2\text{mm}$

## About AddOn Networks

In 1999, AddOn Networks entered the market with a single product. Our founders fulfilled a severe shortage for compatible, cost-effective optical transceivers that compete at the same performance levels as leading OEM manufacturers. Adhering to the idea of redefining service and product quality not previously had in the fiber optic networking industry, AddOn invested resources in solution design, production, fulfillment, and global support.

Combining one of the most extensive and stringent testing processes in the industry, an exceptional free tech support center, and a consistent roll-out of innovative technologies, AddOn has continually set industry standards of quality and reliability throughout its history.

Reliability is the cornerstone of any optical fiber network and is engrained in AddOn's DNA. It has played a key role in nurturing the long-term relationships developed over the years with customers. AddOn remains committed to exceeding industry standards with certifications from ranging from NEBS Level 3 to ISO 9001:2005 with every new development while maintaining the signature reliability of its products.



## U.S. Headquarters

Email: [sales@addonnetworks.com](mailto:sales@addonnetworks.com)

Telephone: +1 877.292.1701

Fax: 949.266.9273

## Europe Headquarters

Email: [salesupportemea@addonnetworks.com](mailto:salesupportemea@addonnetworks.com)

Telephone: +44 1285 842070