

## QSFP56-LB-0BD-AO

MSA and TAA 200GBase QSFP56 Loopback Transceiver with 0dB Attenuation, -40 to 85C

### Features

- SFF-8665 Compliance
- Built-in surge current mitigation technology
- Built-in programmable power dissipation up to 7W
- Industrial temperature: -40 to 85 Celsius
- +3.3V power supply
- Supports 10G/25G/56G PAM4 data rates
- 2-wire interface for integrated Digital Diagnostic Monitoring
- Compliant with IEEE 802.3ba, 802.3bj, and 802.3cd standards
- A multi-color LED indicator for high/low power modes
- Hot Pluggable
- RoHS Compliant and Lead-Free

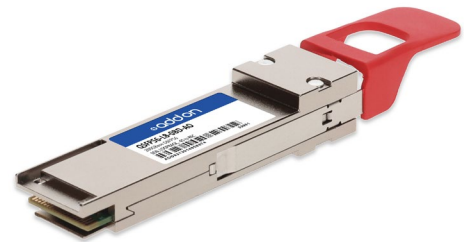

### Product Description

This MSA compliant QSFP56 loopback provides a simple solution to loopback testing on individual ports with the use of a cable assembly. It has 0dB of attenuation and is compatible with existing 200G QSFP56 ports. All of our transceivers are built to comply with Multi-Source Agreement (MSA) standards and are uniquely serialized and tested for data-traffic and application to ensure seamless network integration. This transceiver is Trade Agreements Act (TAA) compliant. We stand behind the quality of our products and proudly offer a limited lifetime warranty.

AddOn's transceivers are RoHS compliant and lead-free.

TAA refers to the Trade Agreements Act (19 U.S.C. & 2501-2581), which is intended to foster fair and open international trade. TAA requires that the U.S. Government may acquire only "U.S. – made or designated country end products."



## Absolute Maximum Ratings

Parameter	Symbol	Min.	Typ.	Max.	Unit	Notes
Maximum Supply Voltage	Vcc	2.97	3.3	3.63	V	
Storage Temperature	Tstg	-40		+85	°C	
Operating Case Temperature	Tc	-40		+85	°C	
Storage Relative Humidity	RHs	0		95	%	
Operating Humidity	RHo	0		85	%	
Data Rate	BRate	0.1		200	Gbps	
Durability Cycles			2000	2250	Cycles	

## Electrical Characteristics

Parameter	Symbol	Min.	Typ.	Max.	Unit	Notes
Differential Input Impedance	Zin	90	100	110	ohm	
Insertion Loss @14GHz	SDD21	3.5		10	dB	1
Insertion Loss Deviation	ILD	-1.0		1.0	dB	2
Return Loss		IEEE 802.3bj CL92.10.3.				
Skew Between Lanes	SKEW			200	ps	
Clock Frequency	fSCL	0		400	KHz	
Clock Stretching	T_clock_hold			500	µs	

### Notes:

1. The insertion loss for TX to RX, including the AC Caps, as measured with MCB. The MCB insertion loss comply with IEEE 802.3bj CL92.11.2.
2. At Nyquist Frequency

## Pin Descriptions

Pin	Symbol	Name/Description	Notes
1	GND	Module Ground.	1
2	Tx2-	Transmitter Inverted Data Input.	
3	Tx2+	Transmitter Non-Inverted Data Input.	
4	GND	Module Ground.	1
5	Tx4-	Transmitter Inverted Data Input.	
6	Tx4+	Transmitter Non-Inverted Data Input.	
7	GND	Module Ground.	1
8	ModSelL	Module Select.	
9	ResetL	Module Reset.	
10	VccRx	+3.3V Receiver Power Supply.	
11	SCL	2-Wire Serial Interface Clock.	
12	SDA	2-Wire Serial Interface Data.	
13	GND	Module Ground.	1
14	Rx3+	Receiver Non-Inverted Data Output.	
15	Rx3-	Receiver Inverted Data Output.	
16	GND	Module Ground.	1
17	Rx1+	Receiver Non-Inverted Data Output.	
18	Rx1-	Receiver Inverted Data Output.	
19	GND	Module Ground.	1
20	GND	Module Ground.	1
21	Rx2-	Receiver Inverted Data Output.	
22	Rx2+	Receiver Non-Inverted Data Output.	
23	GND	Module Ground.	1
24	Rx4-	Receiver Non-Inverted Data Output.	
25	Rx4+	Receiver Inverted Data Output.	
26	GND	Module Ground.	1
27	ModPrsL	Module Present.	
28	IntL	Interrupt.	
29	VccTx	+3.3V Transmitter Power Supply.	
30	Vcc1	+3.3V Power Supply.	
31	LPMode	Low-Power Mode.	
32	GND	Module Ground.	1
33	Tx3+	Transmitter Non-Inverted Data Input.	
34	Tx3-	Transmitter Inverted Data Input.	
35	GND	Module Ground.	1

36	Tx1+	Transmitter Non-Inverted Data Input.	
37	Tx1-	Transmitter Inverted Data Input.	
38	GND	Module Ground.	1

**Notes:**

1. Circuit ground is internally isolated from the chassis ground.

**Electrical Pad Layout**

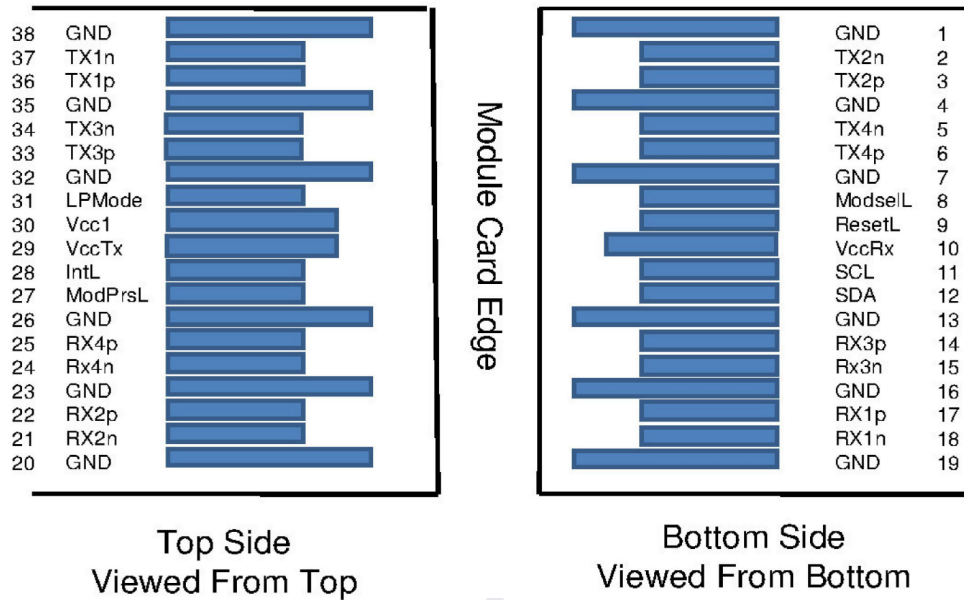

Pin-Out of Connector Block on the Host Board

# Typical Application Circuit

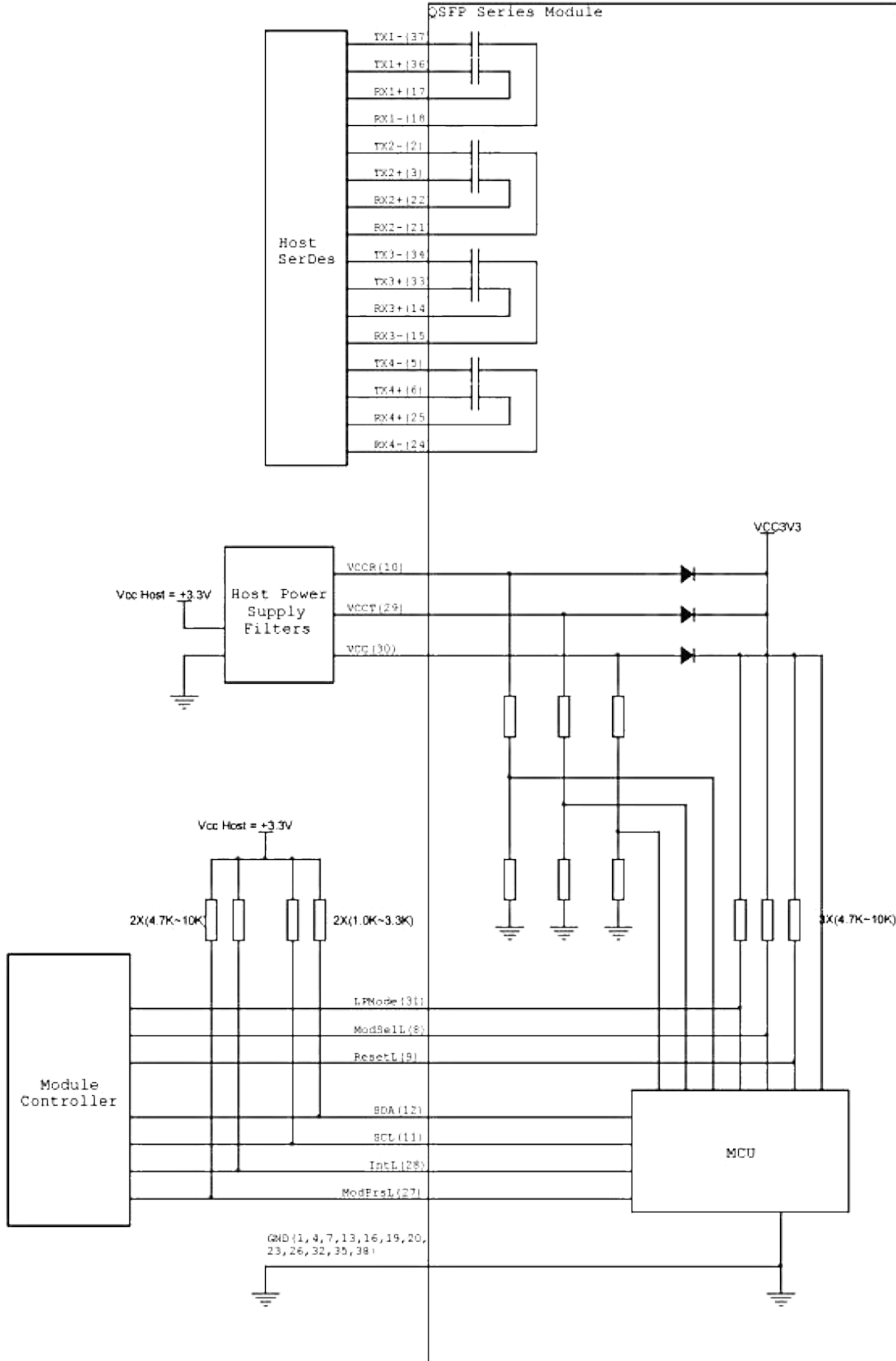

## Status LED

A multi-color LED must be viewed from the front of the module in order to signify high/low power modes, as well as interrupts:

- Solid green: low-power mode
- Solid red: high-power mode
- Blinking green: low-power mode with any of the interrupt flag is set
- Blinking red: high-power mode with any of the interrupt flag is set

## Mechanical Specifications

Dimensions are in millimeters. (Unit: mm)

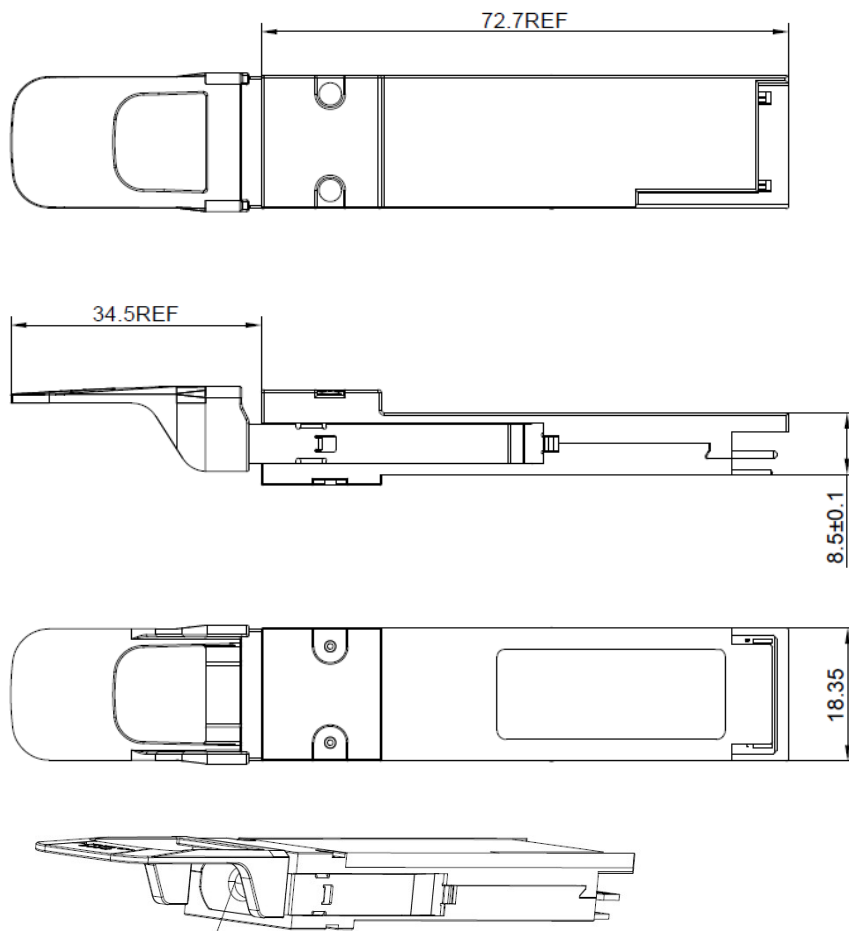

### LED:

Solid green: low-power mode

Solid red: high-power mode

Blinking green: low-power mode with any of the interrupt flag is set

Blinking red: high-power mode with any of the interrupt flag is set

## About AddOn Networks

In 1999, AddOn Networks entered the market with a single product. Our founders fulfilled a severe shortage for compatible, cost-effective optical transceivers that compete at the same performance levels as leading OEM manufacturers. Adhering to the idea of redefining service and product quality not previously had in the fiber optic networking industry, AddOn invested resources in solution design, production, fulfillment, and global support.

Combining one of the most extensive and stringent testing processes in the industry, an exceptional free tech support center, and a consistent roll-out of innovative technologies, AddOn has continually set industry standards of quality and reliability throughout its history.

Reliability is the cornerstone of any optical fiber network and is engrained in AddOn's DNA. It has played a key role in nurturing the long-term relationships developed over the years with customers. AddOn remains committed to exceeding industry standards with certifications from ranging from NEBS Level 3 to ISO 9001:2005 with every new development while maintaining the signature reliability of its products.



## U.S. Headquarters

Email: [sales@addonnetworks.com](mailto:sales@addonnetworks.com)

Telephone: +1 877.292.1701

Fax: 949.266.9273

## Europe Headquarters

Email: [salessupportemea@addonnetworks.com](mailto:salessupportemea@addonnetworks.com)

Telephone: +44 1285 842070