

QSFP28-100GB-SR4-40M-N-AO

Alcatel-Lucent Nokia® Compatible TAA 100GBase-SR4 QSFP28 Transceiver (MMF, 850nm, 40m w/Reduced FEC, MPO, DOM)

Features

- Compliant with IEEE Std 802.3bm, 100G BASE SR4 Ethernet
- Management interface specifications per SFF-8636
- Compliant with QSFP28 MSA
- 4 channels 850nm VCSEL array
- 4 channels PIN photo detector array
- Single MPO connector receptacle
- Class 1 laser safety certified
- Up to 103.1Gb/s data rates
- RoHS Compliant and Lead-Free
- Commercial Temperature: 0 to 70 Celsius



Applications

- 100GBase Ethernet
- Access and Enterprise

Product Description

This Alcatel-Lucent Nokia® compatible QSFP28 transceiver provides 100GBase-SR4 throughput up to 40m w/reduced FEC over OM4 multi-mode fiber (MMF) using a wavelength of 850nm via an MPO connector. It can operate at temperatures between 0 and 70C. Our transceiver is built to meet or exceed OEM specifications and is guaranteed to be 100% compatible with Alcatel-Lucent Nokia®. It has been programmed, uniquely serialized, and tested for data-traffic and application to ensure that it will initialize and perform identically. All of our transceivers comply with Multi-Source Agreement (MSA) standards to provide seamless network integration. Additional product features include Digital Optical Monitoring (DOM) support which allows access to real-time operating parameters. This transceiver is Trade Agreements Act (TAA) compliant. We stand behind the quality of our products and proudly offer a limited lifetime warranty.

AddOn's transceivers are RoHS compliant and lead-free.

TAA refers to the Trade Agreements Act (19 U.S.C. & 2501-2581), which is intended to foster fair and open international trade. TAA requires that the U.S. Government may acquire only "U.S.-made or designated country end products."



Absolute Maximum Ratings

| Parameter | Symbol | Min. | Typ. | Max. | Unit | Notes |
|----------------------------|------------------|------|----------|------|------|-------|
| Power Supply Voltage | V _{CC} | -0.5 | | 4 | V | |
| Storage Temperature | T _{stg} | -40 | | 85 | °C | |
| Case Operating Temperature | T _c | 0 | 25 | 70 | °C | |
| Relative Humidity | RH | 5 | | 95 | % | |
| Data Rate | BR | | 25.78125 | | Gbps | |
| Transmission Distance | TD | | | 40 | m | 1 |
| Transmission Distance | TD | | | 100 | m | 2 |

Notes:

1. On OM4 MMF without host FEC. Or up to 30m on OM3 MMF without host FEC.
2. On OM4 MMF with host Clause 91 (RS) FEC. Or up to 70m on OM3 MMF with host Clause 91 (RS) FEC.

Electrical Characteristics

| Parameter | Symbol | Min. | Typ. | Max. | Unit | Notes |
|--------------------------------|-----------------------|-------|------|-------|-------------------|-------|
| Power Supply Voltage | V _{CC} | 3.135 | 3.3 | 3.465 | V | |
| Power Supply Current | I _{CC} | | | 750 | mA | |
| Power Dissipation | P _D | | | 2.5 | W | |
| Transmitter | | | | | | |
| Input Differential Impedance | Z _{IN} | | 100 | | Ω | |
| Differential Data Input Swing | V _{IN, P-P} | 180 | | 900 | mV _{P-P} | |
| Receiver | | | | | | |
| Output Differential Impedance | Z _O | | 100 | | Ω | |
| Differential Data Output Swing | V _{OUT, P-P} | 300 | | 850 | mV _{P-P} | 1 |
| Transition Time (20% to 80%) | T _{r, Tf} | 12 | | | ps | |

Notes:

1. Internally AC coupled but requires an external 100Ω differential load termination.

Optical Characteristics

| Parameter | Symbol | Min. | Typ. | Max. | Unit | Notes |
|-------------------------------------|-----------------------------|------|------|------|------|-------|
| Transmitter | | | | | | |
| Center Wavelength | λ_C | 840 | 850 | 860 | nm | |
| Optical Launch Power | Po | -4.5 | | +2.4 | dBm | 1 |
| Transmit OMA per Lane | OMA | -4.5 | | +3 | dBm | |
| Extinction Ratio | EX | 2 | | | dB | 2 |
| Spectral Width (RMS) | $\Delta\lambda$ | | | 0.6 | nm | |
| TDEC per Lane | TDEC | | | 4.3 | dB | |
| Optical Return Loss Tolerance | ORLT | | | 12 | dB | |
| Eye Diagram | IEEE Std 802.3bm compatible | | | | | |
| Receiver | | | | | | |
| Receiver Wavelength | λ | 840 | 850 | 860 | nm | |
| Average Receiver Sensitivity (Pavg) | S | | | -7 | dBm | 3 |
| Receiver Overload (Pavg) | POL | 2.4 | | | dBm | |
| Damage Threshold | POL | 3.4 | | | dBm | |
| Optical Reflectance | ORL | | | -12 | dB | |
| LOS De-Assert | LOSD | | | -11 | dBm | |
| LOS Assert | LOSA | -30 | | | dBm | |
| LOS Hysteresis | | 0.5 | | 5 | dB | |

Notes:

1. The optical power is launched into OM3 MMF.
2. Measured with a PRBS $2^{31}-1$ test pattern @25.78125Gbps.
3. Measured with PRBS $2^{31}-1$ test pattern, 25.78125Gb/s, BER<1E-12.

Pin Descriptions

| Pin | Logic | Symbol | Name/Descriptions | Ref. |
|-----|-------------|---------|---|------|
| 1 | | GND | Transmitter Ground. (Common with Receiver Ground.) | 1 |
| 2 | CML-I | Tx2- | Transmitter Inverted Data Input. | |
| 3 | CML-I | Tx2+ | Transmitter Non-Inverted Data Input. | |
| 4 | | GND | Transmitter Ground. (Common with Receiver Ground.) | 1 |
| 5 | CML-I | Tx4- | Transmitter Inverted Data Input. | |
| 6 | CML-I | Tx4+ | Transmitter Non-Inverted Data Input. | |
| 7 | | GND | Transmitter Ground. (Common with Receiver Ground.) | 1 |
| 8 | LVTTTL-I | MODSEIL | Module Select. | 2 |
| 9 | LVTTTL-I | ResetL | Module Reset. | 2 |
| 10 | | VccRx | +3.3V Receiver Power Supply. | |
| 11 | LVC MOS-I | SCL | 2-Wire Serial Interface Clock. | 2 |
| 12 | LVC MOS-I/O | SDA | 2-Wire Serial Interface Data. | 2 |
| 13 | | GND | Transmitter Ground. (Common with Receiver Ground.) | 1 |
| 14 | CML-O | Rx3+ | Receiver Non-Inverted Data Output. | |
| 15 | CML-O | Rx3- | Receiver Inverted Data Output. | |
| 16 | | GND | Transmitter Ground. (Common with Receiver Ground.) | 1 |
| 17 | CML-O | Rx1+ | Receiver Non-Inverted Data Output | |
| 18 | CML-O | Rx1- | Receiver Inverted Data Output. | |
| 19 | | GND | Transmitter Ground. (Common with Receiver Ground.) | 1 |
| 20 | | GND | Transmitter Ground. (Common with Receiver Ground.) | 1 |
| 21 | CML-O | Rx2- | Receiver Inverted Data Output. | |
| 22 | CML-O | Rx2+ | Receiver Non-Inverted Data Output. | |
| 23 | | GND | Transmitter Ground. (Common with Receiver Ground.) | 1 |
| 24 | CML-O | Rx4- | Receiver Inverted Data Output. | |
| 25 | CML-O | Rx4+ | Receiver Non-Inverted Data Output. | |
| 26 | | GND | Transmitter Ground. (Common with Receiver Ground.) | 1 |
| 27 | LVTTTL-O | ModPrsL | Module Present. Internally pulled down to GND. | |
| 28 | LVTTTL-O | IntL | Interrupt output should be pulled up on the host board. | 2 |
| 29 | | VccTx | +3.3V Transmitter Power Supply. | |
| 30 | | Vcc1 | +3.3V Power Supply. | |
| 31 | LVTTTL-I | LPMODE | Low-Power Mode. | 2 |
| 32 | | GND | Transmitter Ground. (Common with Receiver Ground.) | 1 |
| 33 | CML-I | Tx3+ | Transmitter Non-Inverted Data Input. | |
| 34 | CML-I | Tx3- | Transmitter Inverted Data Input. | |
| 35 | | GND | Transmitter Ground. (Common with Receiver Ground.) | 1 |
| 36 | CML-I | Tx1+ | Transmitter Non-Inverted Data Input. | |
| 37 | CML-I | Tx1- | Transmitter Inverted Data Input. | |
| 38 | | GND | Transmitter Ground. (Common with Receiver Ground.) | 1 |

Notes:

1. The module signal grounds are isolated from the module case.
2. This is open collector/drain output that on the host board requires a 4.7KΩ to 10KΩ pull-up resistor to VccHost.

Electrical Pin-Out Details

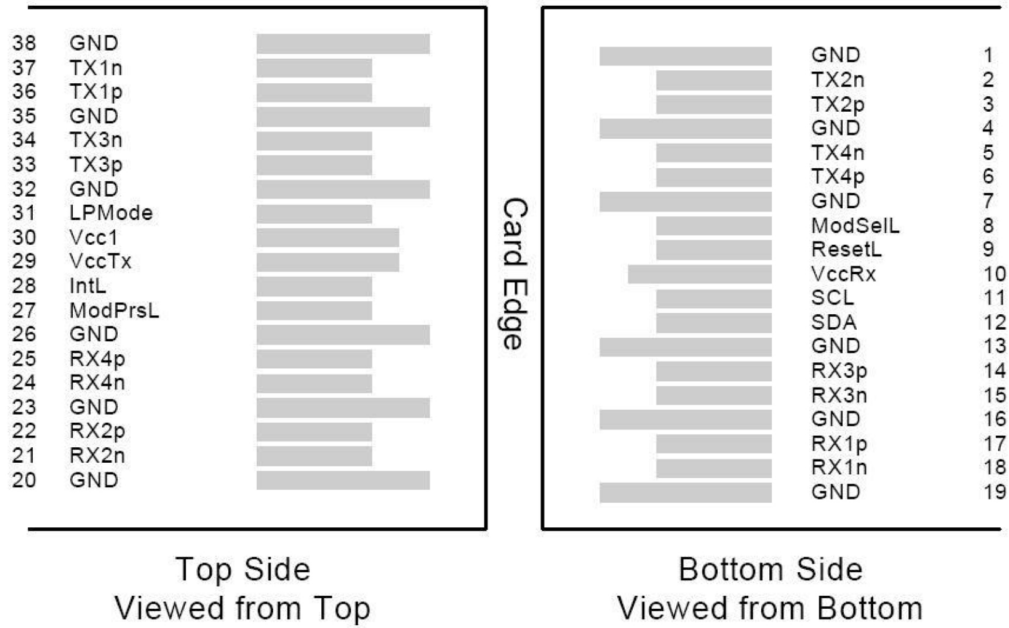

Recommended Host Board Power Supply Filter Network

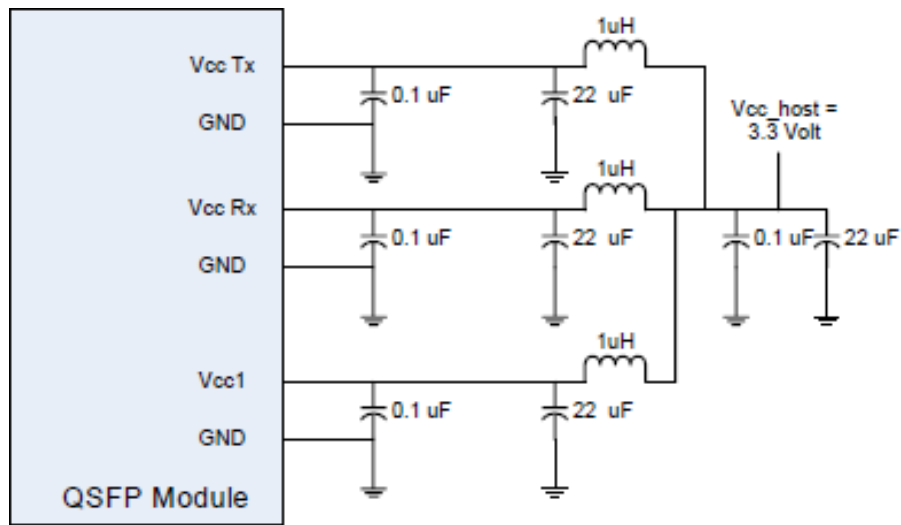

Transceiver Interface Block Diagram

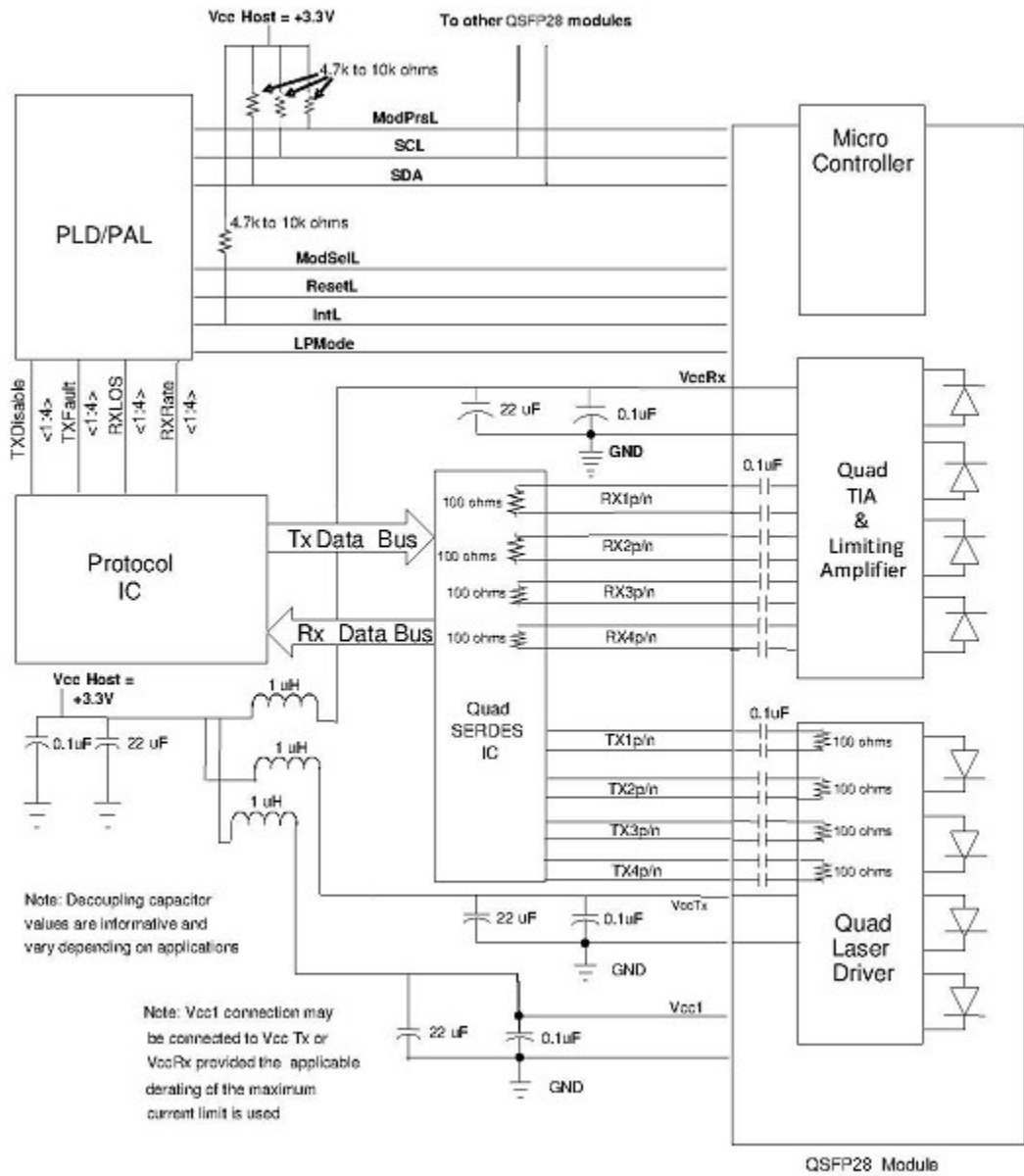

Mechanical Specifications

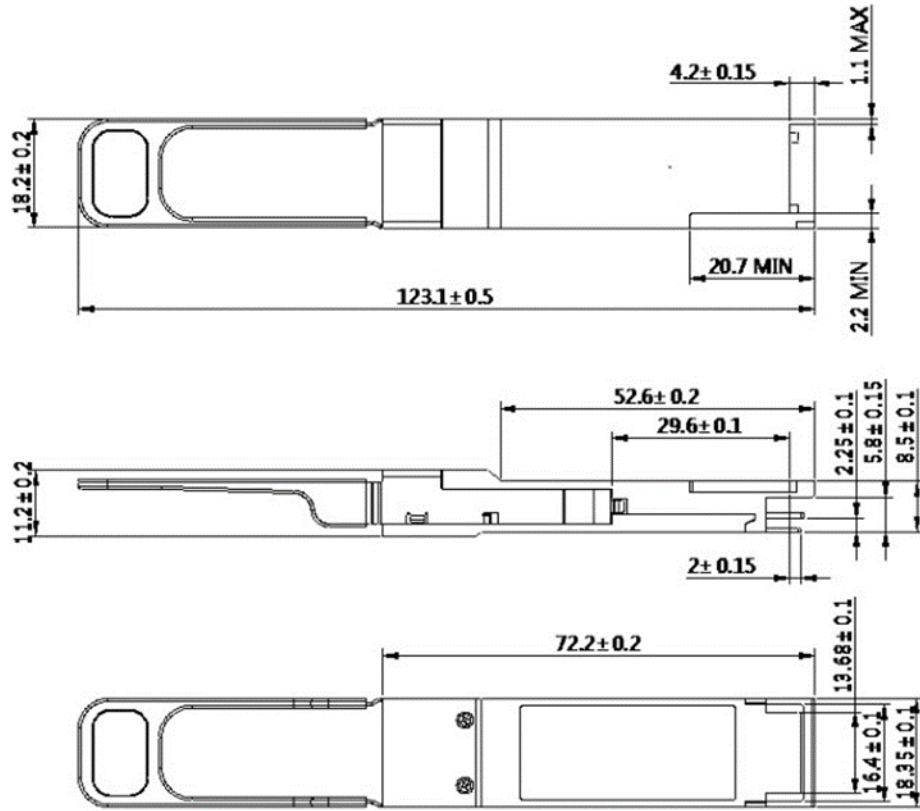

About AddOn Networks

In 1999, AddOn Networks entered the market with a single product. Our founders fulfilled a severe shortage for compatible, cost-effective optical transceivers that compete at the same performance levels as leading OEM manufacturers. Adhering to the idea of redefining service and product quality not previously had in the fiber optic networking industry, AddOn invested resources in solution design, production, fulfillment, and global support.

Combining one of the most extensive and stringent testing processes in the industry, an exceptional free tech support center, and a consistent roll-out of innovative technologies, AddOn has continually set industry standards of quality and reliability throughout its history.

Reliability is the cornerstone of any optical fiber network and is ingrained in AddOn's DNA. It has played a key role in nurturing the long-term relationships developed over the years with customers. AddOn remains committed to exceeding industry standards with certifications ranging from NEBS Level 3 to ISO 9001:2015 with every new development while maintaining the signature reliability of its products.



U.S. Headquarters

Email: sales@addonnetworks.com

Telephone: +1 877.292.1701

Fax: 949.266.9273

Europe Headquarters

Email: salesemea@addonnetworks.com

Telephone: +44 1285 842070